



2025 Exhibitor Booth Space Application & Contract Contract Conditions/Rules & Regulations

This Application & Contract to participate in the Association for the Health Care Environment Exchange Conference & Solution Center (“Event”) at the Greater Columbus Convention Center (“Facility”) over June 8 - 11, 2025, including but not limited to move-in and move out dates (“Event Dates”) shall become effective when it has been submitted by the exhibiting company and accepted by the American Hospital Association for its operating unit, Association for the Health Care Environment (collectively referred to herein for purposes of this Application & Contract as “AHE”). The individual signing this Application & Contract represents and warrants that he/she is duly authorized to execute this binding Application & Contract on behalf of the exhibiting company. By signing below, the exhibiting company agrees to be bound by the terms and conditions below. The exhibiting company agrees that upon acceptance of this Application & Contract by AHE, with or without appropriate payment of the exhibition fee and further action by the exhibiting company, this Application & Contract, together with the terms and conditions below, (collectively “this Contract”) shall become a legally binding contract between AHE and exhibiting company (“Exhibitor”).

1. SHOW MANAGEMENT

Smithbucklin will orchestrate management of Event and will be known as AHE Show Management. Smithbucklin is responsible for assignment of exhibit booth space, exhibit logistics and collection of exhibitor payment. Smithbucklin acts as a liaison between exhibitors, AHE and all official contractors. If you have any questions about your exhibit booth, contact Smithbucklin directly.

Smithbucklin
330 N. Wabash Ave.
Ste. 2000
Chicago, IL 60611 USA
Phone: 312-673-5391
E-mail: AHE@smithbucklin.com

2. EXHIBIT BOOTH COST

For purposes of this Application & Contract, the amount of the rental cost associated with the booth selected by Exhibitor is referred to as the “Exhibit Booth Fee.”

Standard Rate:

\$31.00/sq. ft. or \$3,100 per 10’ x 10’ booth

Premium Rate:

\$38.00/sq. ft. or \$3,800 for first 10’ x 10’ booth and \$31.00/sq. ft. or \$3,100 per each additional 10’ x 10’ booth

Corner Fee:

\$250 per open corner

All inline exhibit booths include 8’ high back drape and 3’ high side drape and a 7”x44” ID sign. All Exhibitors receive a booth # sticker, company listing in the online directory and mobile app, (1) Complimentary Exhibitor Full Conference Badges plus (3) Complimentary Exhibitor Exhibit Hall Only Badges per 10’ x 10’ booth space purchased.

3. ASSIGNMENT OF SPACE

For all Applications & Contracts received on or before Sunday, July 21, 2024, space is assigned via Space Selection the week of July 22, 2024, at the 2024 Exchange Conference & Solution Center in Phoenix, Arizona. For all Applications & Contracts received after the Space Selection is complete, space will be assigned on a first-come, first-served basis.

The priority point system outlined below will be used to assign exhibit space:

1 point per year for AHE Exchange Conference participation since 2002

1 point per 10’ x 10’ booth space at 2024 Exchange Conference & Solution Center (non-cumulative)

5 points for active AHE Membership in 2024 (non-cumulative)

Sponsorships in 2024:

- 8 points for \$50,000+ pledged
- 6 points for \$25,000 - \$49,999 pledged
- 5 points for \$20,000 - \$24,999 pledged
- 4 points for \$15,000 - \$19,999 pledged
- 3 points for \$10,000 - \$14,999 pledged
- 2 points for \$5,000 - \$9,999 pledged
- 1 point for up to \$4,999 pledged

There is a one-year grace period for not exhibiting. If an Exhibitor does not exhibit for two consecutive years (2023 and 2024), all accumulated points are then forfeited. The only points that will carry over year to year will be points for participation as an exhibitor.

If there is a priority point tie, a lottery will be held to see which company selects first. If an Exhibitor changes their name, it is their responsibility to inform AHE Show Management. Because it is nearly impossible to contact all exhibitors for new selections of booth space, AHE Show Management reserves the right to assign the next most suitable space when the requested space is not available. AHE and AHE Show Management also reserves the right, at its sole discretion, to modify the floor plan to accommodate space sales or to avoid conflicts, and, should conditions dictate, AHE reserves the right to adjust the floor plan and relocate exhibit booths as necessary. If payment is not received with an Applications & Contract prior to space selection, your company will not be included in the priority point assignment. The preferences given for booth space locations are guidance and are not guaranteed by AHE.

If an Exhibitor is acquired by another Exhibitor prior to the initial space selection, the Exhibitors may select booth space using the priority point status of the highest Exhibitor if exhibiting together. Priority points are not combined. If an Exhibitor is acquired by another Exhibitor after their initial space selection, the acquired Exhibitor can retain its originally contracted space, move to the acquiring Exhibitor's booth or alternately combine booth square footage and move to a new location. Exhibitors are obligated financially for the total square footage contracted by each Exhibitor. AHE reserves the right to require Exhibitor to provide documentation of acquisition.

All Exhibitors should frequently review their space location and changes to neighboring booths/areas for updates to the floor plan. It is the Exhibitor's responsibility to keep up with changes to their assigned area. AHE anticipates alterations to the initial plan and cannot be held responsible for changes that may affect a participating Exhibitor's selection of space.

AHE Show Management will maintain a waitlist for any Exhibitor who wishes to be placed in a different booth location after their initial selection. To be added to the waitlist, the Exhibitor shall submit a written request, including the requested size of space to AHE@smithbucklin.com Exhibitors are added to the waitlist on a first-come, first-served basis based on date and time of email receipt by AHE Show Management.

AHE reserves the right to change Event hours, schedule or dates, to rearrange the floor plan, and/or to relocate any Exhibitor as it deems necessary at any time.

4. PAYMENTS, CANCELLATIONS & REFUNDS

Exhibitor must remit a 100% percent of their total fees within 30 days of receipt of their invoice from AHE Show Management. Full payment must be received on or before Friday, May 8, 2025, regardless of Applications & Contract submission date. AHE reserves the right to reassign an exhibit booth space if the Exhibitor fails to remit 100% payment by the deadline date.

Credit card payments can be made online using American Express, MasterCard or Visa. Make all checks payable to AHE and remit to the following address via the U.S. Postal Service:

AHE
75 Remittance Drive
Suite 1272
Chicago, IL 60675 USA

Alternatively, Exhibitor may remit via overnight courier (e.g., FedEx) to the following address:

AHA-AHE-91272
5503 North Cumberland Avenue
Chicago, IL 60656 USA

Exhibitors who wish to pay by ACH/wire will require the following information:

Bank: Northern Trust
Bank Location: Chicago, IL
ABA: 071000152
SWIFT: CNORUS44 (for foreign transfers)
Account Name: American Hospital Association
Account #: 78697

The tax ID number is 36-0726140. A W-9 form is available by request. Exhibitors can email Pay Brayley at pbrayley@smithbucklin.com with payment questions or to request a W-9.

AHE reserves the right to hold or revoke Exhibitor badges for any Exhibitor with an unpaid balance and to instruct all official contractors to deny goods and services.

5. CANCELLATION OF FULL OR PARTIAL SPACE BY EXHIBITOR

Cancellation of exhibit space must be directed via email to AHE@smithbucklin.com. For cancellations of space received between the contract submission and Friday, January 24, 2025, Exhibitor is responsible for, and AHE shall be entitled to retain, 50 percent of the total Exhibit Booth Fee as a cancellation fee. Should an Exhibitor cancel a portion of its space between initial space selection and Friday, January 24, 2025, Exhibitor is responsible for, and AHE shall be entitled to retain, 50 percent of the total Exhibit Booth Fee as a cancellation fee.

Full payment is required and no refunds whatsoever will be made on cancellations or reductions of space on or after Friday, January 24, 2025. Should an Exhibitor cancel even partial space on or after Friday, January 24, 2025, the Exhibitor is responsible for the full Exhibit Booth Fee for the originally contracted exhibit space.

Notwithstanding the foregoing, Exhibitor will have no right to cancel all or any portion of assigned exhibitor space or this Applications & Contract subsequent to AHE's cancellation of the Event pursuant to Section 6.

6. CANCELLATION OR CHANGES TO EVENT BY AHE

If for any reason beyond AHE's control AHE determines that the Event must be cancelled, shortened, delayed, dates changed, or otherwise altered or changed, Exhibitor understands and agrees that AHE shall not refund the rental fees paid to it by Exhibitor and that all losses and damages that it may suffer as a consequence thereof are its responsibility and not that of AHE or its directors, officers, employees, agents or subcontractors. Exhibitor understands that it may lose all monies it has paid to AHE for space in the Event, as well as other costs and expenses it has incurred, including travel to the Event, setup, lodging, decorator freight, employee wages, etc.

Exhibitor, as a condition of being permitted by AHE to be an Exhibitor in the Event, agrees to indemnify, defend and hold harmless AHE, its directors, officers, employees, agents and subcontractors from any and all loss which Exhibitor may suffer as a result of Event cancellation, duration, delay or other alterations or changes caused in whole, or in part, by any reason outside AHE's control. The terms of this provision shall survive the termination or expiration of this Applications & Contract.

7. ELIGIBILITY TO EXHIBIT

AHE reserves the right to determine the eligibility of any exhibitor for inclusion in the Event and to prohibit an exhibitor from conducting and maintaining an exhibit if, in the sole judgment of AHE, the exhibitor or exhibit or proposed exhibit shall in any respect be deemed unsuitable. An Exhibitor's eligibility to exhibit in the Event must remain in effect from the time of submission of the Application & Contract to the time of the Event and should AHE determine that an Exhibitor which it had previously determined was eligible to exhibit at the Event is no longer eligible to do so, AHE may notify the Exhibitor and may terminate the Application & Contract without liability upon written notice to Exhibitor. Exhibitors are prohibited from assigning or subletting a booth or any part of the space allotted to them nor shall they exhibit or permit to be exhibited in their space any products or advertising materials for other companies.

8. SUBLETTING OF EXHIBIT SPACE PROHIBITED

Exhibitors are prohibited from assigning or subletting a booth or any part of the space allotted to them nor shall they exhibit or permit to be exhibited in their space any products or advertising materials which are not a part of their own regular products, or which are not compatible with the purpose and/or character of the Event as determined by AHE in its sole discretion.

9. PROMOTIONAL ACTIVITIES

Further, Exhibitors shall not engage in any promotional activities which AHE determines to be outside the purpose and/or character of the Event as determined by AHE in its sole discretion.

10. RETAIL SALES

No retail sales, where payment is received and product delivered, are permitted during the Event at any time. Payment and/or orders may be taken for future delivery.

11. INTELLECTUAL PROPERTY MATTERS

The Exhibitor represents and warrants to AHE that no materials used in or in connection with their exhibit infringe the trademarks, copyrights (including, without limitation, copyrights in music and other materials used or broadcast by Exhibitor) or other intellectual property rights of any third party. The Exhibitor agrees to immediately notify AHE of any information of which the Exhibitor becomes aware regarding actual or alleged infringement of any third party's trademarks, copyrights or other intellectual property rights. The Exhibitor agrees to indemnify, defend and hold AHE, its officers, directors, employees, agents, successors and assigns harmless from and against all losses, damages and costs (including attorney's fees) arising out of or related to claims of infringement by Exhibitor, its employees, agents, or contractors of the trademarks, copyrights and other intellectual property rights of any third party.

Notwithstanding the foregoing, AHE, its officers, directors, employees, agents, and each of them, shall not be liable for and expressly disclaims all liability for infringement or alleged infringement of the trademarks, copyrights or other intellectual property of any third party arising out of the actions of any Exhibitors. The terms of this provision shall survive the termination or expiration of this Contract.

12. USE OF AHE NAME

AHE, AHE logo, AHE Exchange Conference & Solution Center logo and AHE Exchange Conference & Solution Center sponsor logos registered trademarks owned by the AHE. Participation by an Exhibitor in the Event does not entitle the Exhibitor to use such names or logos, except that the Exhibitor may reference the AHE Exchange and use the Event logo with reference to the Exhibitor's participation as an Exhibitor at the AHE Exchange. Participation in the Event does not imply endorsement or approval by AHE of any product, service or participant and none shall be claimed by any participant.

13. SET-UP TIME

Set-up of exhibits begins in the Facility at 8:00 AM, Sunday, June 8, 2025. If an exhibit is not set-up by 2:00 PM, Monday, June 9, 2025, AHE reserves the right to cancel such space, to re-assign such space to another Exhibitor, or to make such other use of the space as deemed necessary or appropriate. AHE reserves the right to set-up the exhibit or remove the freight from the booth at the Exhibitor's expense. No refund will be made to the original contracting Exhibitor. AHE reserves the right to modify move-in/move-out/Exhibit Hours, in which case all Exhibitors will be notified prior to the effective date of such changes.

14. EXHIBIT HOURS

Monday, June 9, 2025
3:00 PM-6:00 PM

Tuesday, June 10, 2025
10:30 AM-2:00 PM

AHE reserves the right to change the Exhibit Hours listed above.

15. DISMANTLING OF EXHIBITS

Exhibits are to be kept intact until the closing of the Exhibit Hall on at 2:00 PM on Tuesday, June 10, 2025. No part of an exhibit shall be removed during the Exhibit Hours without special permission from AHE Show Management. Any Exhibitor who begins dismantling of its booth before the close of the Exhibit Hall may lose part or all of their priority points and may entirely lose the privilege of exhibiting at future AHE events.

All carrier must check-in by PM 4:00 PM on Tuesday, June 10, 2025. All freight must be removed from Facility by 6:00 PM, Tuesday, June 10, 2025. If exhibits are not removed by this time, AHE reserves the right to remove exhibits and charge the expense to the Exhibitor and AHE shall have no liability for any loss or damage to Exhibitor's exhibit property caused by such removal.

16. BADGES

Each Exhibitor is provided (1) complimentary Exhibitor Full Conference badge. Exhibitor Full Conference badges allow access to the exhibit hall for set-up, exhibit hours and dismantle, plus all AHE educational sessions and the Welcome Reception on Sunday, June 8, 2025. In addition, Exhibitors are provided (3) complimentary Exhibitor Exhibit Hall Only badges per 10' x 10' (100 sq. ft.) of exhibit space purchased. Exhibitor Exhibit Hall Only badges allow access to the exhibit hall for set-up, exhibit hours and dismantle only. See grid for badge allotment per booth square footage:

Square Fee	Complimentary Exhibitor Full Conference Badges	Complimentary Exhibitor Exhibit Hall Only Badges
100 sq. ft.	(1) Exhibitor Full Conference Badge	(3) Exhibitor Exhibit Hall Only Badges
200 sq. ft.	(1) Exhibitor Full Conference Badge	(6) Exhibitor Exhibit Hall Only Badges
300 sq. ft.	(1) Exhibitor Full Conference Badge	(9) Exhibitor Exhibit Hall Only Badges
400 sq. ft.	(1) Exhibitor Full Conference Badge	(12) Exhibitor Exhibit Hall Only Badges

All Exhibitor badges are for Exhibitor's full and part time employees or contractors. Co-exhibiting of multiple companies or distributors in one booth is prohibited. Any Exhibitor violating this prohibition may, in AHE's sole discretion, lose part or all its priority points, entirely lose the privilege of exhibiting in future AHE events, have its booth taken away without refund, and/or be charged the full rate for each distributor or company exhibiting in its booth (however briefly they may have been exhibiting). Exhibitor agrees to pay such additional charge immediately upon receipt of AHE's invoice. Exhibitors may not provide a badge to any individual who is not a full or part time employee of the paid Exhibitor. Exhibitors who violate this requirement may, at the sole discretion of AHE, lose part or all its priority points, and may entirely lose the privilege of exhibiting in future AHE events. Unsolicited engagement (e.g. harassing, soliciting, following, etc.) of conference attendees by Exhibitor personnel is prohibited. AHE reserves the right to have said personnel escorted off the premises. Badges for non-exhibiting distribution companies and/or subsidiaries and sub-companies or exhibitors is not permissible. Exhibitor badges allow access to the Exhibit Hall during the following move-in, Exhibit Hours and move-out hours:

Sunday, June 8 (Set-up)

8:00 AM–4:00 PM

Monday, June 9 (Set-up & Exhibit Hall Day 1)

10:00AM–6:00 PM

Tuesday, June 10 (Exhibit Hall Day 2 & Dismantle)

9:00AM–6:00 PM

AHE reserves the right to change the access times listed above.

Registration opens at 12:00 PM on Sunday, June 8, 2025. Prior to this time, Exhibitors must wear a wristband in order to access the Exhibit Hall. Exhibitors may obtain a wristband at the Exhibit Hall Entrance.

Event attendees do not have access to the Exhibit Hall until Monday, June 9, 2025, at 3:00 PM. Exhibitors who give their badges to an Event attendee in order for the attendee to gain access to the Exhibit Hall prior to this time may, at the sole discretion of AHE, lose part or all of its company's priority points, and may entirely lose the privilege of exhibiting in future

AHE events. AHE reserves the right to give an Exhibit Hall pass to any Exhibitor or Event attendee in order to grant them access to the Exhibit Hall at any time.

17. MINIMUM AGE FOR ADMISSION

Children under the age of 16 are not permitted on the Exhibit Hall at any time. Any attendees arriving with children under the age of 16 will be denied access to the Exhibit Hall with such children without any exceptions or refunds.

18. EXHIBITOR LIABILITY

Exhibitor remains solely responsible for the safety of its property at all times during transit to and from the Facility and in the Exhibit Hall. Neither AHE, its directors, officers, employees, agents, subcontractors nor AHE Show Management (collectively "Event Management") are responsible for Exhibitor's property or any loss thereto from any cause.

EXHIBITOR HEREBY WAIVES AND RELEASES ANY CLAIM OR DEMAND IT MAY HAVE AGAINST ANY OF THE EVENT MANAGEMENT BY REASON OF ANY DAMAGE TO OR LOSS OF ANY OF ITS PROPERTY.

19. INDEMNIFICATION

Exhibitor agrees that it will indemnify, defend and hold Event Management, AHE, their respective officers, directors, employees, agents and each of them, harmless from and against a) the performance or breach of this Contract by Exhibitor, its employees, agents or contractors; b) the failure by Exhibitor, its employees, agents or contractors to comply with applicable laws, regulations and ordinances; and c) the act, omission, negligence, gross negligence, or willful misconduct of Exhibitor, its employees, agents, contractors, licensees, guests, or invitees. This indemnification of Event Management by Exhibitor is effective unless such injury was caused by the sole gross negligence or willful misconduct of Event Management. Exhibitor agrees that if Event Management or AHE is made a party to any litigation commenced by or against Exhibitor, or relating to this Contract or the premises leased hereunder, then EXHIBITOR WILL PAY ALL COSTS AND EXPENSES, including attorneys' fees, INCURRED BY OR IMPOSED UPON EVENT MANAGEMENT OR AHE BY REASON OF SUCH LITIGATION. THE TERMS OF THIS PROVISION SHALL SURVIVE THE TERMINATION OR EXPIRATION OF THIS CONTRACT.

20. INSURANCE

Exhibitors are required to maintain and to provide a certificate of insurance to AHE Show Management on or before Thursday, May 8, 2025, evidencing the following:

- (a) General liability with limits not less than \$1,000,000 per occurrence, \$2,000,000 in the aggregate
- (b) Owned (if applicable), hired and non-owned auto liability with limits not less than \$1,000,000 per occurrence
- (c) Workers' compensation with state statutory limits
- (d) Employer's liability with limits not less than \$500,000
- (e) Commercial umbrella liability with limits not less than \$1,000,000
- (f) Personal property and equipment on a special form replacement cost basis

AHE, Smithbucklin Corporation and the Greater Columbus Convention Center are to be listed as additional insureds on a primary and non-contributory basis with respect to general/auto/umbrella liability.

A waiver of subrogation must apply to all policies. All carriers are to maintain an A.M. Best rating of not less than A- VII.

Exhibitors will not be permitted to set up their booth without submitting the proper certificates. Certificates should be sent to:

AHE Show Management
C/O Smithbucklin
330 N. Wabash Ave.
Ste. 2000
Chicago, IL 60611 USA

21. USE OF SPACE — GENERAL

- (a) No Exhibitor is permitted to display or distribute literature or any promotion outside the confines of the assigned exhibit space in the Exhibit Hall. Distribution or display of promotional material in public areas of the Facility or

- meeting rooms is strictly prohibited. AHE also reserves the right to remove, at Exhibitor's cost, any promotional material or product deemed by AHE or AHE Show Management as not suitable for display at the Event.
- (b) Exhibitors are prohibited from possessing, displaying or depicting any products or components or company names in their booth that could be interpreted as being a promotion or comparison (features, benefits, price) of another company.
 - (c) No exhibit will be permitted that interferes with the use of other exhibits or impedes access to them or impedes the free use of the aisles.
 - (d) Distribution by Exhibitors, or their agents, of any printed materials, souvenirs or other articles shall be restricted to the Exhibitor's exhibit space. No noisemakers, helium balloons, lighter-than-air objects, gummed stickers, popcorn, or labels will be permitted as handouts.
 - (e) Any special promotions, music or stunts planned for the Exhibit Hall, must be approved with AHE. Details should be submitted to AHE Show Management via email to AHE@smithbucklin.com at least 10 business days prior to the start of the Event. AHE reserves the right to designate specific days and hours during which special promotions and stunts may be conducted, if they are permitted at all.
 - (f) AHE allows drawings, games of chance and raffles on the Exhibit Hall, subject to the prior written approval of AHE. Exhibitors must abide by all Federal/Ohio/City of Columbus statutes and regulations regarding drawings, games of chance and raffles. Exhibitors should send their approval requests to AHE Show Management via email to AHE@smithbucklin.com.
 - (g) No animals are permitted in the Facility other than service animals.
 - (h) Exhibitors must abide by all of the General Policies, Rules, and Regulations of the Facility, a copy of which is included in the Exhibitor Services Manual, made available to Exhibitors in March 2025. The Facility has reserved the right to update, change or amend its rules and regulations after publication in the Exhibitor Services Manual. To obtain a copy of the General Policies, Rules, and Regulations of the Facility prior to publication in the Exhibitor Services Manual Exhibitor may email AHE@smithbucklin.com.
 - (i) AHE Show Management shall publish health and safety guidelines based on CDC recommendations in the Exhibitor Services Manual. Exhibitor agrees to abide by the guidelines. AHE reserves the right to update, change or amend the guidelines after publication in the Exhibitor Services Manual.
 - (j) All Exhibitors shall be responsible for compliance with the Americans with Disabilities Act. The Exhibitor shall indemnify, defend and hold Event Management harmless from any and all claims, costs, expenses or other damages, arising out of Exhibitor's breach of this provision consequences of Exhibitor's failure in this regard. The terms of this provision shall survive the termination or expiration of this Contract. For more information on the Americans with Disabilities Act and how to make your exhibit accessible to persons with disabilities, please contact:

U.S. Department of Justice ADA, Civil Rights Division Disability Rights Section – NYAV
950 Pennsylvania Avenue, NW
Washington, D.C. 20530 USA
Phone: 800.514.0301 (voice) 800.514.0383 (TTY)
www.ada.gov
 - (k) Any Exhibitor occupying an Island, Split Island, Peninsula or Modified Peninsula space is required to submit a detailed floor plan, including dimensions, to AHE Show Management for review and approval by Thursday, May 8, 2025. All Exhibitors who received a written booth violation notice at the AHE Exchange 2024 are required to submit a detailed floor plan, including dimensions, to AHE Show Management for review and approval by Thursday, May 8, 2025. Floor plans should be submitted via email to AHE@smithbucklin.com.
 - (l) Umbrellas and canopies are considered part of the overall booth components and may not protrude into the aisle.
 - (m) Helium or other compressed gas tanks must be properly secured to prevent toppling. Facility reserves the right to require compressed gas tanks to be removed from the Exhibit Hall during Exhibit Hours. Helium-filled balloons are allowed in the Facility only as a display, and must be fastened to the booth. Balloons may not be given out within the Facility. All lighter-than-air objects must be removed from the Facility at the close of the Event. Both the AHE and Facility reserve the right to assess a fee for retrieving any escaped lighter-than-air objects to the Exhibitor.
 - (n) AHE is the only official housing vendor for the Event. The Expo Group is the only official general service contractor for the Event. Other companies may not provide the prices, service, reliability and availability as AHE and The Expo Group. Exhibitor should make hotel reservations using the information and booking method sent by AHE. AHE shall not be responsible for any damages or costs related to Exhibitor making hotel reservations via an unauthorized

solicitation of hotel reservations or services via an unauthorized vendor solicitation. If there is ever a question about a communication received for hotel reservations or services, check with AHE Show Management by emailing AHE@smithbucklin.com to confirm before taking action.

- (o) All booth personnel must be properly and modestly clothed.
- (p) Exhibitors are permitted to serve food and non-alcoholic beverages in their booth during Exhibit Hours without approval from AHE Show Management. Non-alcoholic beverages do not need to be served by a bartender but all beverages and food must be ordered through the Facility's caterer.
- (q) Exhibitors are permitted to provide alcoholic beverages in their booth, however details should be submitted to AHE Show Management via email to AHE@smithbucklin.com at least 30 business days prior to the start of the Event for review and approval. Alcoholic beverages served in booths may only be purchased and served by licensed bartenders from the Facility's Food and Beverage Department and must be ordered through the Facility's caterer.
- (r) Levy, the official in-house caterer at the Facility, is the exclusive provider of food and/or beverage items at the Facility. If requested, Levy may allow Exhibitors to bring their own food and/or beverage into the Facility for the sole purpose of equipment demonstration, provided the Exhibitor has signed and submitted a sampling waiver and liability form which can be requested by emailing AHE@smithbucklin.com. If Levy needs to handle, store, refrigerate, transport, deliver, prepare, or service any of the demonstration food and beverage product brought in by the Exhibitor, charges will apply. Only food and/or beverages used for Exhibitor's equipment demonstration will be permitted.
- (s) Exhibitors, at AHE's sole discretion, are prohibited from taking videos and photographs of any booths in the Exhibit Hall, other than their own. Aerial photography, videography or stunts of any kind by an Exhibitor, i.e., drones, are strictly prohibited. The Exhibitor acknowledges and agrees that AHE, its employees and contractors may take photographs/videos which could include images of the Exhibitor, its name and logo, its representatives and its exhibits while attending the Event. The Exhibitor hereby consents to and grants to the AHE and its affiliates, the unrestricted, perpetual, worldwide, royalty-free and transferable right and license to use (and grant others the right to use) the images worldwide without any compensation. The Exhibitor acknowledges that AHE is the sole and exclusive owner of all rights in the images and hereby waives (a) any and all rights in and to such images, and (b) any and all claims the Exhibitor and its representatives may have relating to or arising from the images or their use.
- (t) Music in the booth or at any of Exhibitor's function held in conjunction with Event is subject to applicable copyright and licensing fees. It is the sole responsibility of the Exhibitor to pay applicable fees.
- (u) Hanging signs are permitted in all peninsulas, modified peninsulas, split islands and island booths to a maximum height of (16') (4.88 m) to the top of the sign. Hanging signs are NOT permitted in inline booths. See Appendix for additional Booth Construction/Display Rules & Regulations for hanging signs.
- (v) All exhibit fixtures and booth structures are permitted to a maximum height of (8') (2.44 m) in inline booths. All exhibit fixtures and booth structures are permitted to a maximum height of (12') (3.66 m) in all perimeter booths. All exhibit fixtures and booth structures are permitted to a maximum height of (16') (4.88 m) in all peninsulas, modified peninsulas, split islands and island booths. Exhibitor agrees to abide by these maximum height limits and all other Booth Construction/Display Rules & Regulations as outlined in the Appendix.
- (w) In order to ensure the success of the Event and avoid dilution of benefits extended to all partners, Exhibitor may not extend invitations, call meetings or otherwise encourage absence of other exhibitor's/sponsors attendees from any program or other component of the Event during the official hours of the Event or any function sponsored in connect with the Event by AHE without prior notice to and approval by AHE.

22. USE OF SPACE — LIGHTS/ AUDIO, ETC.

- (a) No spotlight may be directed toward the aisles or so directed that it proves to be irritating or distracting to neighboring Exhibitors or guests.
- (b) Droplights or special lighting devices must be hung at a level or positioned so as not to prove to be an irritant or distraction to neighboring Exhibitors or guests.
- (c) No strobe light effects are permitted.
- (d) Projectors, computer screens or TV screens must not cause people to block the aisle. Computer screens and TV screens are considered part of the overall booth components and may not protrude into the aisle.
- (e) Loud speakers or operation of equipment which is of excessive sound volume to be annoying to neighboring Exhibitors or guests is not permitted based on the 80/80 Rule: Any sound that consistently exceeds 80 decibels

measured at the edge of an Exhibitor's booth or is clearly identifiable more than 80 feet from that booth is considered objectionable.

- (f) No lighting, fixtures, lighting trusses, or overhead lighting are allowed outside the boundaries of the exhibit space. All lighting should be directed to the inner confines of the booth space. Lighting should not project onto other exhibits or aisles. Exhibitors intending to use hanging light systems are required to submit a detailed floor plan with light locations and dimensions, including height, of all items in the booth, to Event Management for review and approval by Thursday, May 8, 2025.
- (g) Vehicles may not be displayed without prior written approval from AHE and the Facility Public Safety Department.

23. DISPLAYS OUTSIDE EXHIBIT AREA

Absolutely no exhibits are permitted outside the Facility. There are to be no displays in hotel rooms, hotel public areas or other facilities or areas contracted or used by AHE.

24. HOTEL ROOMS, SUITES & MEETING ROOMS

AHE reserves the right to control all suites and meeting rooms in the Facility and in those hotels participating in the AHE housing block. These controls have already been set up with each property. The Meeting Space Request Form should be used to submit requests for function space, including meeting and hospitality rooms. You may submit your application for meeting space online on the 'Exhibitor Resource' page of the website. No meetings, private functions, including lunch meetings, or entertainment can be scheduled during Event Hours (6:00PM–8:00PM on Sunday, June 8, 2025; 8:00AM–6:00PM on Monday, June 9, 2025; 6:45AM–4:30PM on Tuesday, June 10, 2025; and 8:00AM–12:30PM on Wednesday, June 11, 2025). No product displays or demonstrations are permitted in meeting rooms. Activities that conflict with the nature of the Event are not permitted. Suites and meeting rooms are assigned on a first-come, first-served basis and only to Exhibitors and organizations allied with AHE.

25. ATTENDEE LISTS

Attendee lists from the Event are distributed only to exhibiting companies and include limited data. Please note that no other individual or organization are authorized to market or to sell attendee lists of AHE. Such lists shall only be used for mailings of promotional material relating to Exhibitor's booth at the Event and shall not be reproduced, transferred or used in any other manner. In using such lists for mailings, Exhibitors must ensure compliance with all country, state and local laws and regulations including, but not limited to, the European Union's General Data Protection Regulations (GDPR and the California Consumer Privacy Act (CCPA). The Exhibitor shall indemnify, hold AHE, its directors, officers, employees, agents or subcontractors harmless from the performance or breach of this provision by Exhibitor, its employees, agents or contractors. The terms of this provision shall survive the termination or expiration of this Contract.

26. FIRE REGULATIONS

- (a) All materials used in exhibit booth(s) must be of a non-flammable nature. Electric signs and equipment must be wired to meet the specifications of the Facility and the City of Columbus Fire Department.
- (b) Any Exhibitor having equipment that produces heat, smoke or open flames as an integral part of product demonstration must provide ventilation, safety equipment and proper insulation and utility connections meeting all local fire regulations. Such Exhibitors must receive written approval of plans from the Facility, the City of Columbus Fire Department and from AHE.
- (c) A complete list of all fire safety regulations is included in the Exhibitor Services Manual. The Facility's public safety department and City of Columbus Fire Department has reserved the right to update, change or amend its rules and regulations after publication in the Exhibitor Services Manual. To obtain a copy of the fire regulations prior to publication in the Exhibitor Services Manual Exhibitor may email AHE@smithbucklin.com.

27. LABOR RELATIONS

- (a) Full-time employees of exhibiting companies may set up their own exhibits without assistance from the local union. Any labor services that may be required beyond what your regular full-time employees can provide must be rendered by union personnel and can be ordered in advance through The Expo Group. Proof of full-time employment status may be requested by the Union Steward of any personnel working in your booth.
- (b) If Exhibitors intend to use an Exhibitor Appointed Contractor (EAC) to install and/or dismantle their booth, the Exhibitor must register their EAC no later than Thursday, May 8, 2025. An EAC registration form is provided in the

Exhibitor Services Manual. An original Certificate of Insurance must be filed with AHE in order for any EACs to gain access to the Exhibit Hall. All EACs are required to wear both a Facility Access Credential and individual Event credentials at all times.

- (c) Exhibitors may hand carry their own materials into the exhibit facility. The use or rental of dollies, flat trucks and other mechanical equipment, however, is not permitted. The Expo Group controls access to the loading docks in order to provide for a safe and orderly move-in/out. Only full-time employees of the exhibiting company are allowed to hand carry items. Unloading and reloading at the dock of any and all contracted carriers are handled by the General Services Contractor. A dock is provided for use by privately operated vehicles.
- (d) No one under the age of 18 is permitted in loading dock, truck bays or loading dock yard.
- (e) AHE, The Expo Group, and the Facility has reserved the right to update, change or amend these Labor Relation rules and regulations after publication in the Exhibitor Services Manual.

28. EXHIBITOR SERVICES MANUAL

In March, The Expo Group distributes an Exhibitor Services Manual to each Exhibitor that provides Exhibitors with complete shipping instructions, production information, and other forms for all services needed during set-up, Exhibit Hours and dismantle. The Expo Group discount deadline is Thursday, May 8, 2025.

29. WARRANTIES

AHE makes no warranties, either express or implied, as to the availability or suitability of the contractors, services and/or equipment of the Facility, AHE, or their respective employees, agents or contractors.

30. AMENDMENTS/ INTERPRETATION

AHE reserves the right to amend and enforce this Contract. Written notice of any amendments shall be given to each affected Exhibitor. Each Exhibitor, for itself, its agents and employees, agrees to abide by this Contract set forth therein, or by any subsequent amendments. AHE reserves the sole right to interpret this Contract. All interpretations are final and are not subject to review or to appeal. Exhibitors which, in the sole interpretation of AHE shall be subject to disciplinary action up to and including ejection from the Event and refusal to participate in any future events or Events of AHE or AHA.

31. ENFORCEMENT/ MISCELLANEOUS

This Contract is governed by Illinois law and the Exhibitor consents to the exclusive jurisdiction of the State and Federal courts seated in Cook County, Illinois, with respect to any action arising out of this Contract or AHE. The parties explicitly acknowledge and agree that the provisions of this Contract are both reasonable and enforceable. However, the provisions of this Contract are severable and, as such, the invalidity of any one or more provisions shall not affect or limit the enforceability of the remaining provisions. Should any provision be held unenforceable for any reason, then such provision shall be enforced to the maximum extent permitted by law.

This Contract will be binding on the Exhibitor's heirs, successors and assigns.

32. LIMITATION OF LIABILITY

IN NO EVENT SHALL THE FACILITY, THE AHE EXCHANGE, AHE , THEIR OWNERS, MANAGERS, OFFICERS OR DIRECTORS, AGENTS, EMPLOYEES, INDEPENDENT CONTRACTORS, SUBSIDIARIES AND AFFILIATES (COLLECTIVELY "AHE PARTIES") BE LIABLE TO THE EXHIBITOR OR ANY THIRD PARTY HIRED BY OR OTHERWISE ENGAGED BY THE EXHIBITOR FOR ANY LOST PROFITS OR ANY OTHER INDIRECT, SPECIAL, PUNITIVE, EXEMPLARY, INCIDENTAL OR CONSEQUENTIAL DAMAGES, INCLUDING ATTORNEY'S FEES AND COSTS, ARISING OUT OF THIS APPLICATION & CONTRACT OR CONNECTED IN ANY WAY WITH USE OF OR INABILITY TO USE THE SERVICES OUTLINED IN THIS APPLICATION & CONTRACT OR FOR ANY CLAIM BY EXHIBITOR, EVEN IF ANY OF THE AHE PARTIES HAVE BEEN ADVISED, ARE ON NOTICE, AND/OR SHOULD HAVE BEEN AWARE OF THE POSSIBILITY OF SUCH DAMAGES. EXHIBITOR AGREES THAT AHE PARTIES' SOLE AND MAXIMUM LIABILITY TO EXHIBITOR, REGARDLESS OF THE CIRCUMSTANCES, SHALL BE THE REFUND OF THE EXHIBIT BOOTH FEE. EXHIBITOR AGREES TO INDEMNIFY AND DEFEND THE AHE PARTIES FROM ANY CLAIMS BROUGHT BY A THIRD PARTY HIRED BY, OR ENGAGED BY THE EXHIBITOR FOR ANY AMOUNT BEYOND THE EXHIBIT BOOTH FEE. FURTHER, EXHIBITOR AGREES TO PAY ALL ATTORNEY'S FEES AND COSTS INCURRED BY AHE PARTIES ARISING OUT OF, OR IN ANY WAY RELATED TO, THIS CONTRACT. EXHIBITOR SHALL BE SOLEY RESPONSIBLE FOR ITS ATTORNEY'S FEES AND COSTS.

BOOTH CONSTRUCTION | DISPLAY RULES AND REGULATIONS

STANDARD INLINE BOOTH

Inline booths have only one side exposed to an aisle and are generally arranged in a series along a straight line. Individual booths may be combined to form a larger inline booth space.

Dimensions

For purposes of consistency and ease of layout, all inline booths are 10' (3.05m) across the front and 10' (3.05m) deep.

Use of Space

Regardless of the number of inline booths utilized, e.g. 10' by 20' (3.05m by 6.10m), 10' by 30' (3.05m by 9.14m), 10' by 40' (3.05m by 12.19m) etc., display materials should be arranged in such a manner as not to obstruct sight lines of neighboring Exhibitors. The maximum height of 8' (2.44m) is allowed in the rear of the booth space, with a 4' (1.22m) height restriction imposed on all materials within 5' (1.52m) of an aisle. When two (2) or more inline booths are used in combination as a single exhibit space, the 4' (1.22m) height limitation is applied only to that portion of exhibit space which is within 10' (3.05m) of an adjoining booth.

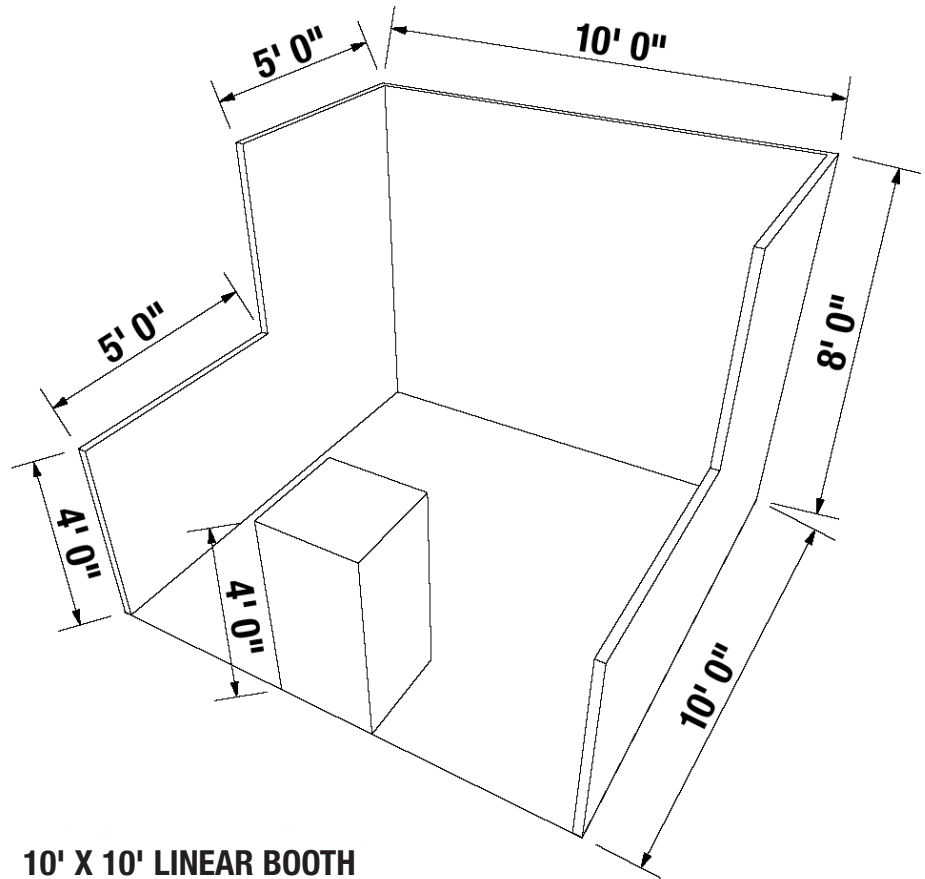

10' X 10' LINEAR BOOTH

CORNER BOOTH

A corner booth is an inline booth exposed to aisles on two (2) sides. All other guidelines for inline booths apply.

PERIMETER BOOTH

A perimeter booth is an inline booth that backs up to an outside wall of the exhibit facility rather than to another exhibit. All guidelines for inline booths apply to perimeter booths with the exception that the maximum back wall height is 12' (3.66m).

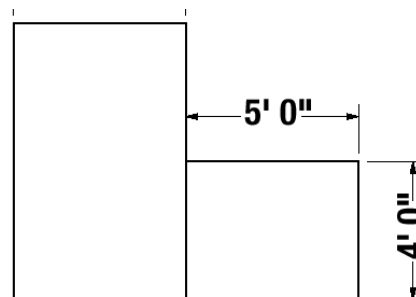

LEFT SIDE

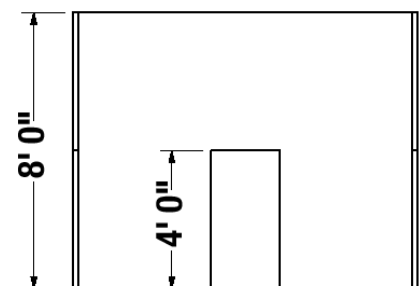

FRONT

BOOTH CONSTRUCTION | DISPLAY RULES AND REGULATIONS

PENINSULA BOOTH

A peninsula booth is exposed to aisles on three (3) sides and composed of a minimum of four (4) booths. When combining booths to create a peninsula booth, any service aisle space becomes part of the usable booth space. Backwalls must be finished and cannot contain copy. There are two (2) primary types of peninsula booths: one which backs up to inline booths and one which backs up to another peninsula booth and is referred to as a split island booth.

Dimensions

A peninsula booth is usually 20' wide (6.10m). When a peninsula booth backs up to two (2) inline booths, the backwall is restricted to 4' (1.22m) in height within 5' (1.52m) of the aisle and 10' (3.05m) of the adjoining booths. 20' (6.0m) is the maximum height allowance for the center portion of the backwall, exhibit fixtures, components and identification signs.

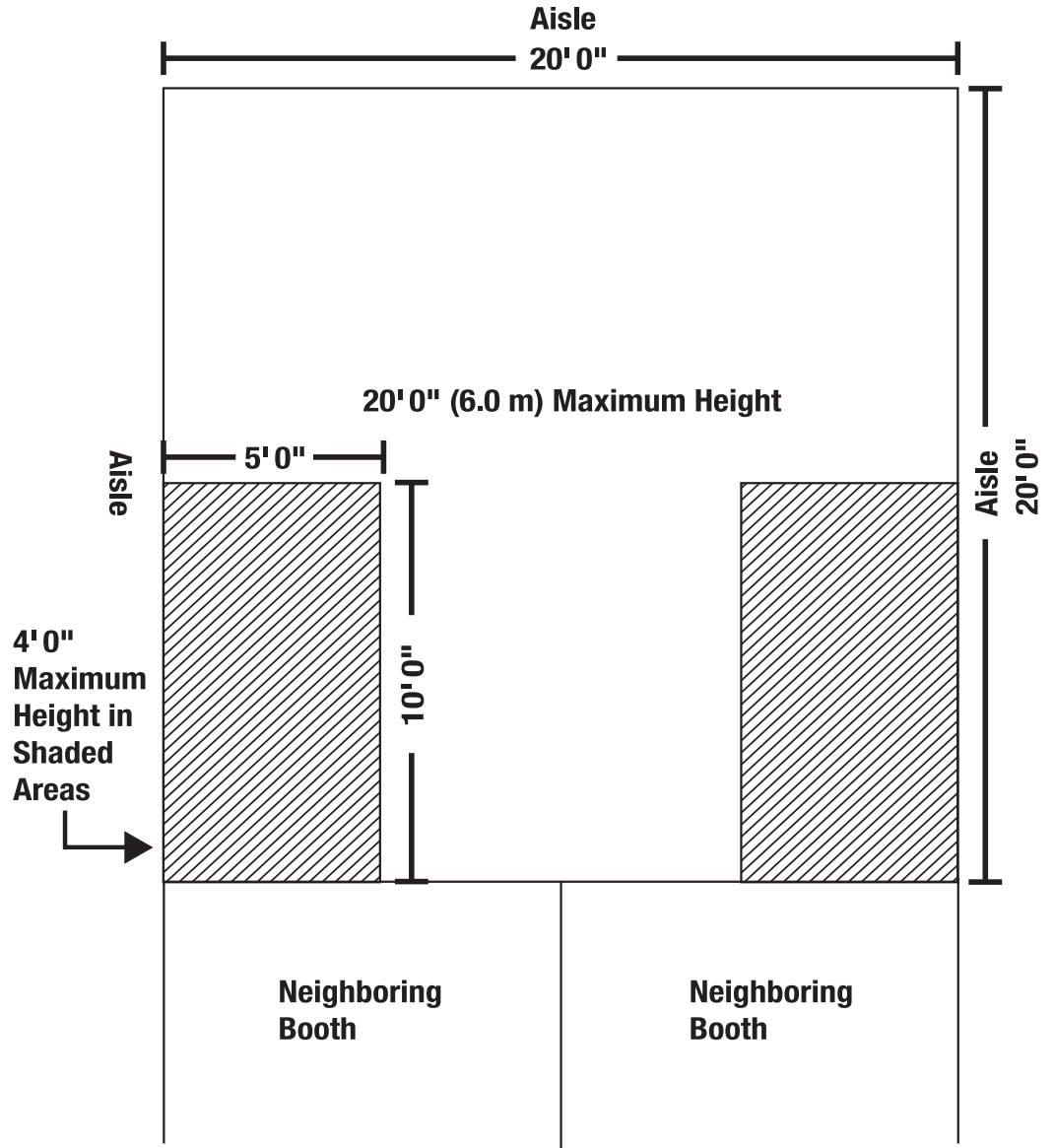

BOOTH CONSTRUCTION | DISPLAY RULES AND REGULATIONS

SPLIT ISLAND BOOTH

A split island booth is a peninsula booth that shares a common backwall with another peninsula booth. The entire cubic content of this booth may be used up to the maximum content of 20' (6.0m), including signage. Backwalls must be finished and can not contain copy.

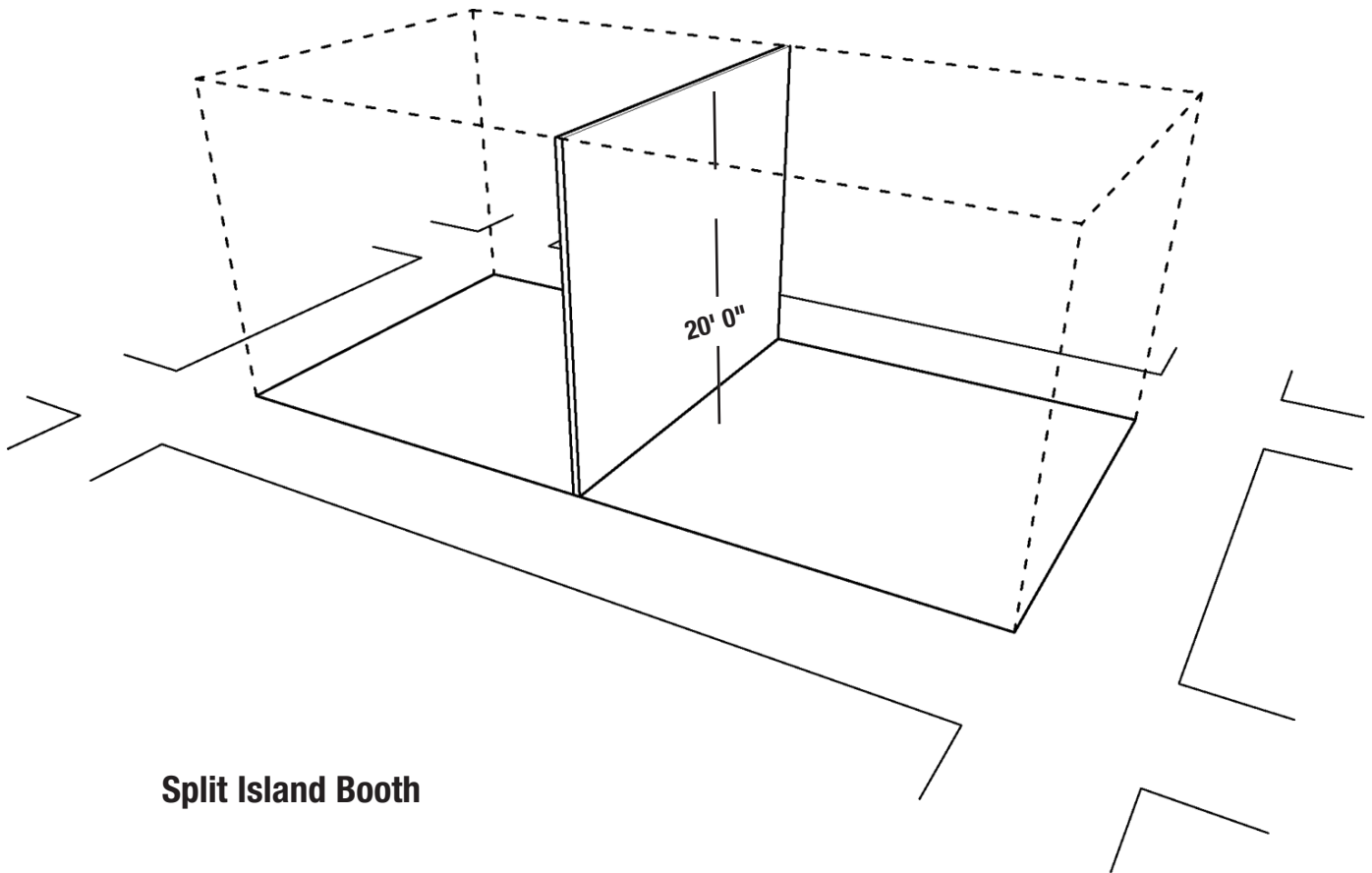

BOOTH CONSTRUCTION | DISPLAY RULES AND REGULATIONS

ISLAND BOOTH

An island booth is any size booth exposed to aisles on all four (4) sides. The entire cubic content of this booth may be used up the maximum content of 20' (6.0m), including signage.

Exhibitors may delete booths from the floor plan to form an island only, and only, if the total number of booths on both sides of the aisle totals 400 square feet or more (see diagram below).

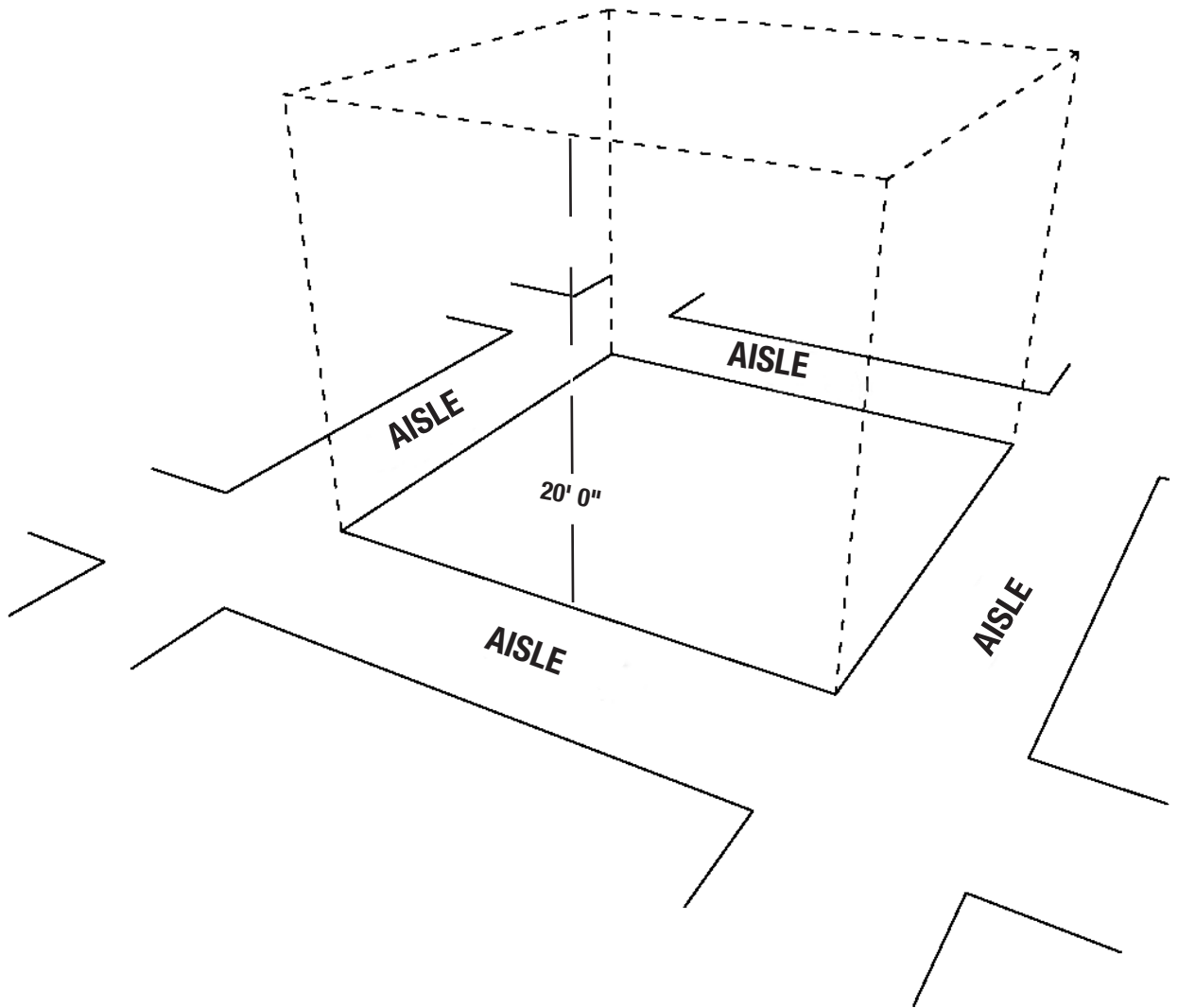

IMPORTANT BOOTH CONSTRUCTION DISPLAY CONSIDERATIONS

CANOPIES & CEILINGS

Canopies, including ceilings, umbrellas and canopy frames, can be either decorative or functional (such as to shade computer monitors from ambient light or for hanging products). Canopies for inline or perimeter booths should comply with line of sight requirements and may not protrude into the aisle.

The base of the canopy should not be lower than 7' (2.13m) from the floor within 5' (1.52m) of any aisle. Canopy supports should be no wider than 3" (7.62cm). This applies to any booth configuration that has a sightline restriction, such as an inline booth. Fire and safety regulations for the convention center may apply to canopies and ceilings and will be included in the Exhibitor Services Manual made available to Exhibitors 90 days prior to show opening. The convention center has reserved the right to update, change or amend its rules and regulations after publication in the Exhibitor Services Manual.

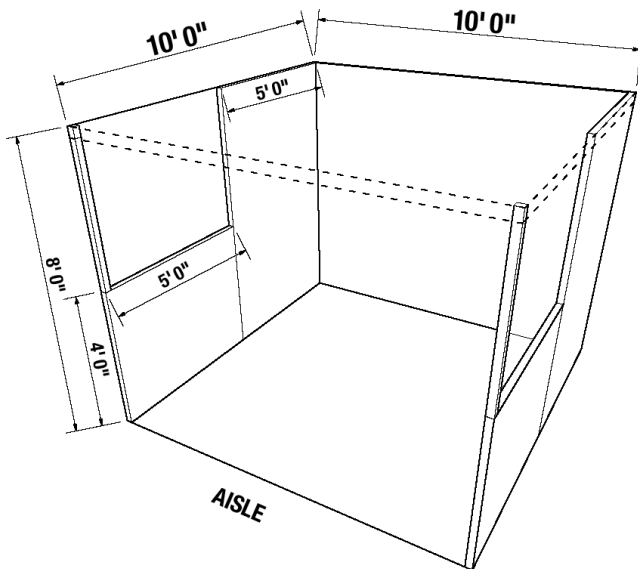

**10' X 10' INLINE BOOTH
with Canopy**

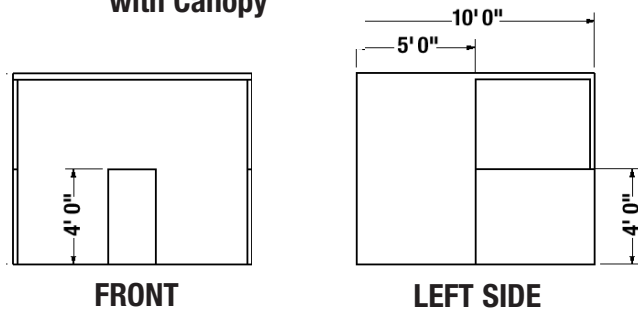

HANGING SIGNS & GRAPHICS

Hanging signs and graphics are permitted in all peninsula, modified peninsula, split island and island booths to a maximum height of 20' (6.10m) to the top of the sign. Whether suspended from above or supported from below, they should comply with all use-of-space requirements. If within 5' (1.53m) of an adjacent booth, and if the placement complies with the use-of-space requirements, the side facing the adjacent booth should be finished and not contain any copy.

MULTI-STORY EXHIBITS

A multi-story exhibit is permitted in all peninsula, modified peninsula, split island and island booths to a maximum height of 20' (6.10m). Multi-story exhibits require approval and building permits from the convention center and the fire marshal. Exhibitors should obtain permits early on to ensure that all time constraints are met. Additional information will be included in the Exhibitor Services Manual made available to Exhibitors 90 days prior to show opening.

ISSUES COMMON TO ALL BOOTH TYPES

STRUCTURAL INTEGRITY

All exhibit displays should be designed and erected in a manner that will withstand normal contact or vibration caused by neighboring Exhibitors, hall labors or installation/dismantling equipment such as fork lifts. Displays should be able to withstand moderate wind effects that may occur in the Exhibit Hall when freight doors are open. Exhibitor should ensure that any display fixtures such as tables, racks or shelves are designed and installed properly to support the product or marketing materials to be displayed upon them.

FLAMMABLE AND TOXIC MATERIALS

All materials used in display construction and decorating should be made of fire retardant materials and be certified as flame retardant. Exhibitors should dispose of any waste products they generate during the exhibition in accordance with guidelines established by the Environmental Protection Agency (EPA) and the facility.

STORAGE

Fire regulations prohibit storing product, literature, empty packing containers or packing materials behind drapes. In most cases, however, Exhibitors may store a limited supply of literature or product appropriately within the booth area, as long as these items do not impede access to utility services, create a problem or look unsightly.