



AMERICAN
SOCIETY FOR
HEALTH CARE
RISK
MANAGEMENT

2024 Exhibitor Contract Terms & Conditions

This Application & Contract to participate the ASHRM Annual Conference (“Event”) at the San Deigo Convention Center (“Facility”) over October 6 – 9, 2024, including but not limited to move-in and move out dates (“Event Dates”) shall become effective when it has been submitted by the exhibiting company and accepted by ASHRM. The individual signing this Application & Contract represents and warrants that he/she is duly authorized to execute this binding Application & Contract on behalf of the exhibiting company. By submitting an Application & Contract, the exhibiting company agrees to be bound by the terms and conditions below. The exhibiting company agrees that upon acceptance of this Application & Contract by ASHRM with or without appropriate payment of the exhibition fee and further action by the exhibiting company, this Application & Contract, together with the Terms & Conditions (T&Cs) below, (collectively “this Contract”) shall become a legally binding contract between ASHRM and exhibiting company (“Exhibitor”).

1. EVENT MANAGEMENT

Smithbucklin will orchestrate management of Event and will be known as ASHRM Event Management. Smithbucklin is responsible for assignment of exhibit booth space, exhibit logistics and collection of exhibitor payment. Smithbucklin acts as a liaison between exhibitors, ASHRM and all official contractors. If you have any questions about your exhibit booth, contact Smithbucklin directly.

Smithbucklin

330 N. Wabash Ave.

Ste. 2000

Chicago, IL 60611 USA

Phone: 312-673-5607

E-mail: ASHRM@smithbucklin.com

2. BOOTH RENTAL FEE

\$30.00 per square foot / \$3,000 per 10’x10’

\$200 corner fee

ASHRM also offers a turnkey exhibit booth package for \$42.00 per square foot / \$4,200 per 10’x10’ that includes (1) one standard booth carpet in black, (1) one 6’ long 30” high skirted table in black, (2) two side chairs and (1) wastebasket.

For purposes of this Contract, the amount of the rental cost associated with the booth selected by Exhibitor is referred to as the “Exhibit Booth Fee.”

3. ASSIGNMENT OF SPACE

For all Applications and Contracts received on or before October1, 2023, space is assigned at the 2023 Annual Conference during the Onsite Space Selection on October 2 – 3, 2023.

For all Applications & Contracts received after Onsite Space Selection is complete, space will be assigned on a first-come, first-served basis.

Priority Points:

1 point – Sponsorship(s)* valued up to \$5,000

2 points – Each 10’ x 10’ booth purchased for the ASHRM Annual Conference

2 points – Each previous consecutive ASHRM Annual Conference in which exhibiting company has participated

6 points – Sponsorship(s)* valued at \$45,000

4 points – Sponsorship(s)* valued at \$30,000

2 points – Sponsorship(s)* valued at \$20,000

*Sponsorship points applied to space assignments for the ASHRM 2024 Annual Conference are those sponsorship points earned from sponsorships purchased for the ASHRM 2023 Annual Conference. Sponsorship points earned for Sponsorships purchased for the ASHRM 2024 Annual Conference will be applied to the ASHRM 2025 Annual Conference.

If an Exhibitor is acquired by another Exhibitor prior to the initial space selection, the Exhibitors may select booth space using the priority point status of the highest Exhibitor if exhibiting together. Priority points are not combined. If an Exhibitor is acquired by another Exhibitor after their initial space selection, the acquired Exhibitor can retain its originally contracted space, move to the acquiring Exhibitor's booth or alternately combine booth square footage and move to a new location. Exhibitors are obligated financially for the total square footage contracted by each Exhibitor. ASHRM reserves the right to require Exhibitor to provide documentation of acquisition.

All Exhibitors should frequently review their space location and changes to neighboring booths/areas for updates to the floor plan. It is the Exhibitor's responsibility to keep up with changes to their assigned area. ASHRM anticipates alterations to the initial plan and cannot be held responsible for changes that may affect a participating Exhibitor's selection of space.

ASHRM will maintain a waitlist for any Exhibitor who wishes to be placed in a different booth location after their initial selection. To be added to the waitlist, the Exhibitor shall submit a written request, including the requested size of space to ASHRM@smithbucklin.com. Exhibitors are added to the waitlist on a first-come, first- served basis based on date and time of email receipt by ASHRM Show Management.

ASHRM reserves the right to change Event Hours or dates, to rearrange the floor plan, and/or to relocate any Exhibitor as it deems necessary at any time.

4. PAYMENTS, CANCELLATIONS & REFUNDS

Exhibitor must remit a 100% percent of their total fee within 30 days of receipt of their invoice from ASHRM Event Management. Full payment must be received on or before August 30, 2024, regardless of Contract submission date.

Credit card payments can be made online using American Express, MasterCard or Visa. Make all checks payable to Association for Healthcare Resource & Materials Management (ASHRM 2024) Event and remit to the following address via the U.S. Postal Service:

American Society for Health Care Risk Management (ASHRM)
75 Remittance Drive
Suite 1272
Chicago, IL 60675 USA

Alternatively, Exhibitor may remit via overnight courier (e.g., FedEx) to the following address:

AHA-ASHRM-91272
5503 North Cumberland Avenue
Chicago, IL 60656 USA

Exhibitors who which to pay by ACH/wire will require the following information:

Bank: Northern Trust
Bank Location: Chicago, IL
ABA: 071000152
SWIFT: CNORUS44 (for foreign transfers)
Account Name: American Hospital Association
Account #: 78697

A W-9 form is available by request. Exhibitors can email Pay Brayley at pbrayley@smithbucklin.com with payment questions or to request a W-9.

ASHRM reserves the right to hold or revoke Exhibitor badges for any Exhibitor with an unpaid balance and to instruct all official contractors to deny goods and services.

5. CANCELLATION OF FULL OR PARTIAL SPACE BY EXHIBITOR

Cancellation of exhibit space must be directed via email to ASHRM@smithbucklin.com. For cancellations of space received between the initial space selection and May 3, 2024, Exhibitor is responsible for, and ASHRM shall be entitled to retain, 50 percent of the total Exhibit Booth Fee as a cancellation fee. Should an Exhibitor cancel a portion of its space between initial space selection and May 3, 2024, Exhibitor is responsible for, and ASHRM shall be entitled to retain, 50 percent of the total Exhibit Booth Fee as a cancellation fee.

Full payment is required and no refunds whatsoever will be made on cancellations or reductions of space on or after May 3, 2024. Should an Exhibitor cancel even partial space on or after May 3, 2024, the Exhibitor is responsible for the full Exhibit Booth Fee for the originally contracted exhibit space.

Notwithstanding the foregoing, Exhibitor will have no right to cancel all or any portion of assigned exhibitor space or this Applications & Contract subsequent to ASHRM's cancellation of the Event pursuant to Section 6.

6. CANCELLATION OR CHANGES TO EVENT BY ASHRM

If for any reason beyond ASHRM's control ASHRM determines that ASHRM Event must be cancelled, shortened, delayed, dates changed, or otherwise altered or changed, Exhibitor understands and agrees that ASHRM shall not refund the Exhibit Booth Fee paid to it by Exhibitor and that all losses and damages that it may suffer as a consequence thereof are its responsibility and not that of ASHRM, ASHRM Event Management, or its directors, officers, employees, agents or subcontractors. Exhibitor understands that it may lose all monies it has paid to ASHRM for space in the Event, as well as other costs and expenses it has incurred, including travel to the Event, setup, lodging, decorator freight, employee wages, etc.

Exhibitor, as a condition of being permitted by ASHRM to be an Exhibitor in the Event, agrees to indemnify, defend and hold harmless ASHRM, its directors, officers employees, agents and subcontractors from any and all loss which Exhibitor may suffer as a result of Event cancellation, duration, delay or other alterations or changes caused in whole, or in part, by any reason outside ASHRM's control. The terms of this provision shall survive the termination or expiration of this Contract.

7. ELIGIBILITY TO EXHIBIT

ASHRM reserves the right to determine the eligibility of any exhibitor for inclusion in the Event and to prohibit an exhibitor from conducting and maintaining an exhibit if, in the sole judgment of ASHRM, the exhibitor or exhibit or proposed exhibit shall in any respect be deemed unsuitable. An Exhibitor's eligibility to exhibit in the Event must remain in effect from the time of submission of the Application & Contract to the time of the Event and should ASHRM determine that an Exhibitor which it had previously determined was eligible to exhibit at the Event is no longer eligible to do so, ASHRM may notify the Exhibitor and may terminate the Application & Contract without liability upon written notice to Exhibitor. Exhibitors are prohibited from assigning or subletting a booth or any part of the space allotted to them nor shall they exhibit or permit to be exhibited in their space any products or advertising materials for other companies.

8. SUBLETTING OF EXHIBIT SPACE PROHIBITED

Exhibitors are prohibited from assigning or subletting a booth or any part of the space allotted to them nor shall they exhibit or permit to be exhibited in their space any products or advertising materials which are not a part of their own regular products, or which are not compatible with the purpose and/or character of The ASHRM Event as determined by ASHRM in its sole discretion.

9. PROMOTIONAL ACTIVITIES

Further, Exhibitors shall not engage in any promotional activities, which ASHRM determines to be outside the purpose and/or character of the ASHRM Event as determined by ASHRM in its sole discretion.

10. RETAIL SALES

No retail sales, where payment is received and product delivered, are permitted during the Event at any time. Payment and/or orders may be taken for future delivery.

11. INTELLECTUAL PROPERTY MATTERS

The Exhibitor represents and warrants to ASHRM that no materials used in or in connection with their exhibit infringe the trademarks, copyrights (including, without limitation, copyrights in music and other materials used or broadcast by Exhibitor) or other intellectual property rights of any third party. The Exhibitor agrees to immediately notify ASHRM of any information of which the Exhibitor becomes aware regarding actual or alleged infringement of any third party's trademarks, copyrights or other intellectual property rights. The Exhibitor agrees to indemnify, defend and hold ASHRM, its officers, directors, employees, agents, successors and assigns harmless from and against all losses, damages and costs (including attorney's fees) arising out of or related to claims of infringement by Exhibitor, its employees, agents, or contractors of the trademarks, copyrights and other intellectual property rights of any third party.

Notwithstanding the foregoing, ASHRM, its officers, directors, employees, agents, and each of them, shall not be liable for and expressly disclaims all liability for infringement or alleged infringement of the trademarks, copyrights or other intellectual property of any third party arising out of the actions of any Exhibitors. The terms of this provision shall survive the termination or expiration of this Contract.

12. USE OF ASHRM NAME

ASHRM, ASHRM Annual Conference and the Event logo are registered trademarks owned by ASHRM. Participation by an Exhibitor in the Event does not entitle the Exhibitor to use such names or logos, except that the Exhibitor may reference the ASHRM Annual Conference and use the Event logo with reference to the Exhibitor's participation as an Exhibitor at the ASHRM Annual Conference. Participation in the Event does not imply endorsement or approval by ASHRM of any product, service or participant and none shall be claimed by any participant.

13. SET-UP TIME

Set-up of exhibits begins in the Facility on October 5, 2024, at 8:00 am. If an exhibit is not set-up by 3:00 pm on October 6, 2024, ASHRM reserves the right to cancel such space, to re-assign such space to another Exhibitor, or to make such other use of the space as deemed necessary or appropriate. ASHRM reserves the right to set-up the exhibit or remove the freight from the booth at the Exhibitor's expense. No refund will be made to the original contracting Exhibitor. ASHRM reserves the right to modify move-in/move-out/Event Hours, in which case all Exhibitors will be notified prior to the effective date of such changes.

14. EVENT HOURS

Sunday, October 6, 2024

5:15 pm – 7:00 pm

Monday, October 7, 2024

8:00 am – 9:00 am

11:30 am – 1:00 pm

4:45 pm – 6:30 pm

Tuesday, October 8, 2024

8:00 am – 9:00 am

12:00 pm – 2:00 pm

ASHRM reserves the right to change the Event Hours listed above.

15. DISMANTLING OF EXHIBITS

Exhibits are to be kept intact until the closing of the Event on October 8, 2024, 2:00 pm. No part of an exhibit shall be removed during the Event without special permission from ASHRM Event Management. Any Exhibitor who begins dismantling of its booth before the close of the Event may lose part or all of their priority points and may entirely lose the privilege of exhibiting at future ASHRM events.

All freight must be removed from Facility on October 9, 2024, by 11:00 pm. If exhibits are not removed by this time, ASHRM reserves the right to remove exhibits and charge the expense to the Exhibitor and ASHRM shall have no liability for any loss or damage to Exhibitor’s exhibit property caused by such removal.

16. BADGES

Exhibitors are provided (3) complimentary Exhibitor badges per (100) sq. ft. of exhibit space purchased, with a minimum of (3) badges per company. See grid for badge allotment per booth square footage:

Booth Size in Square Feet Number of Complimentary Badges

100 sq. ft.	3
200 sq. ft.	6
300 sq. ft.	9
400 sq. ft.	12
600 sq. ft.	18

Exhibitors are provided (1) complimentary Exhibitor Full Conference badges for access to Solution Center and education sessions per (100) sq. ft. of exhibit space purchased.

All Exhibitor badges are for Exhibitor’s full and part time employees or contractors. Exhibitor badges allow access to the Solution Center during the following move-in, Event and move-out hours, please note these dates and times are subject to change:

- Saturday, October 5, 2024
8:00 am – 5:00 pm
- Sunday, October 6, 2024
8:00 am – 7:00 pm
- Monday, October 7, 2024
7:00 am – 6:30 pm
- Tuesday, October 8, 2024
7:00 am – 6:00 pm
- Wednesday, October 9, 2024
8:00 am – 12:00 pm

Event attendees do not have access to the Solution Center until October 6 at 5:15 pm. Exhibitors who give their badges to an Event attendee in order for the attendee to gain access to the Solution Center prior to this time may, at the sole discretion of ASHRM, lose part or all of its company’s priority points, and may entirely lose the privilege of exhibiting in future ASHRM events. ASHRM reserves the right to give a Solution Center pass to any Exhibitor or Event attendee in order to grant them access to the Solution Center at any time.

17. MINIMUM AGE FOR ADMISSION

Children under the age of 16 are not permitted on the Solution Center at any time. Any attendees arriving with children under the age of 16 will be denied access to the Solution Center with such children without any exceptions or refunds.

18. EXHIBITOR LIABILITY

Exhibitor remains solely responsible for the safety of its property at all times during transit to and from the Facility and in the Solution Center. Neither ASHRM, its directors, officers, employees, agents, subcontractors nor ASHRM Event Management (collectively “Show Management”) are responsible for Exhibitor’s property or any loss thereto from any cause.

EXHIBITOR HEREBY WAIVES AND RELEASES ANY CLAIM OR DEMAND IT MAY HAVE AGAINST ANY OF SHOW MANAGEMENT BY REASON OF ANY DAMAGE TO OR LOSS OF ANY OF ITS PROPERTY.

19. INDEMNIFICATION

Exhibitor agrees that it will indemnify, defend and hold Show Management harmless from and against a) the performance or breach of this Contract by Exhibitor, its employees, agents or contractors; b) the failure by Exhibitor, its employees, agents or contractors to comply with applicable laws, regulations and ordinances; and c) the act, omission, negligence, gross negligence, or willful misconduct of Exhibitor, its employees, agents, contractors, licensees, guests, or invitees. This indemnification of Show Management by Exhibitor is effective unless such injury was caused by the sole gross negligence or willful misconduct of Show Management. Exhibitor agrees that if Show Management or ASHRM is made a party to any litigation commenced by or against Exhibitor, or relating to this Contract or the premises leased hereunder, then EXHIBITOR WILL PAY ALL COSTS AND EXPENSES, including attorneys' fees, INCURRED BY OR IMPOSED UPON SHOW MANAGEMENT OR ASHRM BY REASON OF SUCH LITIGATION. THE TERMS OF THIS PROVISION SHALL SURVIVE THE TERMINATION OR EXPIRATION OF THIS CONTRACT.

20. INSURANCE

Exhibitors are required to maintain and to provide a certificate of insurance to ASHRM Event Management on or before August 30, 2024, evidencing the following:

- (a) General liability with limits not less than \$1,000,000 per occurrence, \$2,000,000 in the aggregate
- (b) Owned (if applicable), hired and non-owned auto liability with limits not less than \$1,000,000 per occurrence
- (c) Workers' compensation with state statutory limits
- (d) Employer's liability with limits not less than \$500,000
- (e) Commercial umbrella liability with limits not less than \$5,000,000
- (f) Personal property and equipment on a special form replacement cost basis

ASHRM, Smithbucklin Corporation, The Expo Group and the San Diego Convention Center are to be listed as additional insureds on a primary and non-contributory basis with respect to general/auto/umbrella liability.

A waiver of subrogation must apply to all policies. All carriers are to maintain an A.M. Best rating of not less than A- VII.

Exhibitors will not be permitted to set up their booth without submitting the proper certificates. Certificates should be sent to:

ASHRM Event Management
C/O Smithbucklin
330 N. Wabash Ave.
Ste. 2000
Chicago, IL 60611 USA

21. USE OF SPACE — GENERAL

- (a) No Exhibitor is permitted to display or distribute literature or any promotion outside the confines of the assigned exhibit space in the Solution Center. Distribution or display of promotional material in public areas of the Facility or meeting rooms is strictly prohibited. ASHRM also reserves the right to remove, at Exhibitor's cost, any promotional material or product deemed by ASHRM or ASHRM Event Management as not suitable for display at the Event.
- (b) Exhibitors are prohibited from possessing, displaying or depicting any products or components or company names in their booth that could be interpreted as being a promotion or comparison (features, benefits, and price) of another company.
- (c) No exhibit will be permitted that interferes with the use of other exhibits or impedes access to them or impedes the free use of the aisles.
- (d) Distribution by Exhibitors, or their agents, of any printed materials, souvenirs or other articles shall be restricted to the Exhibitor's exhibit space. No noisemakers, helium balloons, lighter-than-air objects, gummed stickers, popcorn, or labels will be permitted as handouts.
- (e) Any special promotions, music or stunts planned for the Solution Center, must be approved with ASHRM. Details should be submitted to ASHRM Event Management via email to ASHRM@smithbucklin.com at least 10 business days

prior to the start of the Event. ASHRM reserves the right to designate specific days and hours during which special promotions and stunts may be conducted, if they are permitted at all.

- (f) ASHRM allows drawings, games of chance and raffles in the Solution Center, subject to the prior written approval of ASHRM. Exhibitors must abide by all San Deigo and State of California statutes and regulations regarding drawings, games of chance and raffles.
- (g) No animals are permitted in the Facility other than service animals.
- (h) Exhibitors must abide by all of the General Policies, Rules, and Regulations of the Facility, a copy of which is included in the Exhibitor Services Manual. The Facility has reserved the right to update, change or amend its rules and regulations after publication in the Exhibitor Services Manual. To obtain a copy of the General Policies, Rules, and Regulations of the Facility prior to publication in the Exhibitor Services Manual Exhibitor may email ASHRM@smithbucklin.com.
- (i) ASHRM Event Management shall publish health and safety guidelines based on CDC recommendations and the Facility General Policies, Rules, and Regulations in the Exhibitor Services Manual. Exhibitor agrees to abide by the guidelines. ASHRM reserves the right to update, change or amend the guidelines after publication in the Exhibitor Services Manual.
- (j) All Exhibitors shall be responsible for compliance with the Americans with Disabilities Act. The Exhibitor shall indemnify, defend and hold Event Management harmless from any and all claims, costs, expenses or other damages, arising out of Exhibitor's breach of this provision consequences of Exhibitor's failure in this regard. The terms of this provision shall survive the termination or expiration of this Contract. For more information on the Americans with Disabilities Act and how to make your exhibit accessible to persons with disabilities, please contact:

U.S. Department of Justice ADA, Civil Rights Division Disability Rights Section – NYAV
950 Pennsylvania Avenue, NW
Washington, D.C. 20530 USA
Phone: 800-514-0301 (voice) 800-514-0383 (TTY)
www.ada.gov
- (k) Any Exhibitor occupying an Island, Split Island, Peninsula or Modified Peninsula space is required to submit a detailed floor plan, including dimensions, to ASHRM Event Management for review and approval by August 30, 2024. All Exhibitors who received a written booth violation notice at the Event in 2023 are required to submit a detailed floor plan, including dimensions, to ASHRM Event Management for review and approval by August 30, 2024. Floor plans should be submitted via email to ASHRM@smithbucklin.com.
- (l) Umbrellas and canopies are considered part of the overall booth components and may not protrude into the aisle.
- (m) Any compressed gas tanks must be ordered through facility Exhibitor Services and must be properly secured to prevent toppling. Facility reserves the right to require compressed gas tanks to be removed from the Solution Center during Event Hours. Balloons may not be given out within the Facility. All lighter-than-air objects must be removed from the Facility at the close of the Event. Both the ASHRM and Facility reserve the right to assess a fee for retrieving any escaped lighter-than-air objects to the Exhibitor.
- (n) ASHRM shall not be responsible for any damages or costs related to Exhibitor making hotel reservations via an unauthorized solicitation of hotel reservations.
- (o) All booth personnel must be properly and modestly clothed.
- (p) Sodexo Live!, the official in-house caterer and at the Facility is the exclusive provider of food and/or beverage items at the Facility. If requested, Sodexo Live! may allow Exhibitors to bring their own food and/or beverage into the Facility for the sole purpose of equipment demonstration, provided the Exhibitor has signed and submitted a sampling and waiver of liability form, which can be found in the Exhibitor Services Manual or by emailing ASHRM Event Management at ASHRM@smithbucklin.com. If Sodexo Live! is required to handle, store, refrigerate, transport, deliver, prepare, or service any of the demonstration food and beverage product brought in by the Exhibitor, charges will apply. Only food and/or beverages used for Exhibitor's equipment demonstration will be

permitted. Any Exhibitor who wished to order food or beverages for their booth must obtain approval from ASHRM Event Management.

- (q) All booth floors must be finished. Exposed concrete is not acceptable. Booth carpet order forms are included in the Exhibitor Services Manual.
- (r) Exhibitors, at ASHRM's sole discretion, are prohibited from taking videos and photographs of any booths in the Solution Center, other than their own. Aerial photography, videography or stunts of any kind by an Exhibitor, i.e., drones, are strictly prohibited. The Exhibitor acknowledges and agrees that the ASHRM, its employees and contractors may take photographs/videos, which could include images of the Exhibitor, its name and logo, its representatives and its exhibits while attending the Exhibition. The Exhibitor hereby consents to and grants to the ASHRM and its affiliates, the unrestricted, perpetual, worldwide, royalty-free and transferable right and license to use (and grant others the right to use) the images worldwide without any compensation. The Exhibitor acknowledges that ASHRM is the sole and exclusive owner of all rights in the images and hereby waives (a) any and all rights in and to such images, and (b) any and all claims the Exhibitor and its representatives may have relating to or arising from the images or their use.
- (s) Music in the booth or at any of Exhibitor's function held in conjunction with the Event is subject to applicable copyright and licensing fees. It is the sole responsibility of the Exhibitor to pay applicable fees.
- (t) Hanging signs are permitted in all peninsulas, modified peninsulas, split islands and island booths to a maximum height of (20') (6.0 m) to the top of the sign. Hanging signs are NOT permitted in inline booths. See Appendix for additional Booth Construction/Display Rules & Regulations for hanging signs.
- (u) All exhibit fixtures and booth structures are permitted to a maximum height of (8') (2.44 m) in inline booths. All exhibit fixtures and booth structures are permitted to a maximum height of (12') (3.66 m) in all perimeter booths. All exhibit fixtures and booth structures are permitted to a maximum height of (20') (6.0 m) in all peninsulas, modified peninsulas, split islands and island booths. Exhibitor agrees to abide by these maximum height limits and all other Booth Construction/Display Rules & Regulations as outlined in the Appendix.
- (v) In order to ensure the success of the Event and avoid dilution of benefits extended to all partners, Exhibitor may not extend invitations, call meetings or otherwise encourage absence of other exhibitors/sponsors attendees from any program or other component of the Event during the official hours of the Event or any function sponsored in connect with the Event by ASHRM without prior notice to and approval by ASHRM.

22. USE OF SPACE — LIGHTS/ AUDIO, ETC.

- (a) No spotlight may be directed toward the aisles or so directed that it proves to be irritating or distracting to neighboring Exhibitors or guests.
- (b) Droplights or special lighting devices must be hung at a level or positioned so as not to prove to be an irritant or distraction to neighboring Exhibitors or guests.
- (c) No strobe light effects are permitted.
- (d) Projectors, computer screens or TV screens must not cause people to block the aisle. Computer screens and TV screens are considered part of the overall booth components and may not protrude into the aisle.
- (e) Loud speakers or operation of equipment which is of excessive sound volume to be annoying to neighboring Exhibitors or guests is not permitted based on the 80/80 Rule: Any sound that consistently exceeds 80 decibels measured at the edge of an Exhibitor's booth or is clearly identifiable more than 80 feet from that booth is considered objectionable.
- (f) No lighting, fixtures, lighting trusses, or overhead lighting are allowed outside the boundaries of the exhibit space. All lighting should be directed to the inner confines of the booth space. Lighting should not project onto other exhibits or aisles. Exhibitors intending to use hanging light systems are required to submit a detailed floor plan with light locations and dimensions, including height, of all items in the booth, to Event Management for review and approval by August 28, 2024.

- (g) Vehicles may not be displayed without prior written approval from ASHRM and the Facility Public Safety Department.

23. DISPLAYS OUTSIDE EXHIBIT AREA

Absolutely no exhibits are permitted outside the Facility. There are to be no displays in hotel rooms, hotel public areas or other facilities or areas contracted or used by ASHRM.

24. HOTEL ROOMS, SUITES & MEETING ROOMS

ASHRM reserves the right to control all suites and meeting rooms in the Facility and in those hotels participating in the ASHRM housing block. These controls have already been set up with each property. The Meeting/Function Space Application is included in the Exhibitor Services Manual to submit requests for function space, including meeting and hospitality rooms. No meetings, private functions, including lunch meetings, or entertainment can be scheduled during Event Hours. No product displays or demonstrations are permitted in meeting rooms. Activities that conflict with the nature of ASHRM's Annual Conference are not permitted. Suites and meeting rooms are assigned on a first-come, first-served basis and only to Exhibitors and organizations allied with ASHRM.

25. ATTENDEE LISTS

Attendee lists from the Event are distributed only to exhibiting companies, other official partners and attendees. Please note that no other individual or organization are authorized to market or to sell attendee lists of ASHRM. Such lists shall only be used for mailings of promotional material relating to Exhibitor's booth at the Event and shall not be reproduced, transferred or used in any other manner. In using such lists for mailings, Exhibitors must ensure compliance with all country, state and local laws and regulations including, but not limited to, the European Union's General Data Protection Regulations (GDPR and the California Consumer Privacy Act (CCPA). The Exhibitor shall indemnify, hold ASHRM, its directors, officers, employees, agents or subcontractors harmless from the performance or breach of this provision by Exhibitor, its employees, agents or contractors. The terms of this provision shall survive the termination or expiration of this Contract.

26. FIRE REGULATIONS

- (a) All materials used in exhibit booth(s) must be of a non-flammable nature. Electric signs and equipment must be wired to meet the specifications of the Facility and the Fire Department.
- (b) A complete list of all fire regulations is included in the Exhibitor Services Manual. The Fire Department has reserved the right to update, change or amend its rules and regulations after publication in the Exhibitor Services Manual.

27. LABOR RELATIONS

- (a) Full-time employees of exhibiting companies may set up their own exhibits without assistance from the local union. Any labor services that may be required beyond what your regular full-time employees can provide must be rendered by union personnel and can be ordered in advance through The Expo Group. Proof of full-time employment status may be requested by the Union Steward of any personnel working in your booth.
- (b) If Exhibitors intend to use an Exhibitor Appointed Contractor (EAC) to install and/or dismantle their booth, the Exhibitor must register their EAC no later than September 6, 2024. An EAC registration form is provided in the Exhibitor Services Manual. An original Certificate of Insurance must be filed with ASHRM in order for any EACs to gain access to the Solution Center. All EACs are required to wear both a Facility Access Credential and individual event credentials at all times. The Facility follows the ESCA (Exhibition Service Contractors Association) Badging System.
- (c) Exhibitors may hand carry their own materials into the exhibit facility. The use or rental of dollies, flat trucks and other mechanical equipment, however, is not permitted. The Expo Group controls access to the loading docks in order to provide for a safe and orderly move-in/out. Only full-time employees of the exhibiting company are allowed to hand carry items. Unloading and reloading at the dock of any and all contracted carriers are handled by the General Services Contractor. A dock is provided for use by privately operated vehicles.
- (d) The Facility and The Expo Group have reserved the right to update, change or amend the labor rules outlined above. ASHRM shall inform all Exhibitors of any changes or amendments.

28. EXHIBITOR SERVICES MANUAL

In June, the general services contractor for the ASHRM Annual Conference, The Expo Group, distributes an Exhibitor Services Manual to each Exhibitor that provides Exhibitors with complete shipping instructions, production information, and other forms for all services needed during installation, Event days and dismantle. The discount deadline for the ASHRM Annual Conference is September 6, 2024.

29. WARRANTIES

ASHRM makes no warranties, either express or implied, as to the availability or suitability of the contractors, services and/or equipment of the Facility, ASHRM, or their respective employees, agents or contractors.

30. AMENDMENTS/ INTERPRETATION

ASHRM reserves the right to amend and enforce this Contract. Written notice of any amendments shall be given to each affected Exhibitor. Each Exhibitor, for itself, its agents and employees, agrees to abide by this Contract set forth therein, or by any subsequent amendments. ASHRM reserves the sole right to interpret this Contract. All interpretations are final and are not subject to review or to appeal. Exhibitors which, in the sole interpretation of ASHRM shall be subject to disciplinary action up to and including ejection from the Event and refusal to participate in any future events or Events of ASHRM.

31. ENFORCEMENT/ MISCELLANEOUS

This Contract is governed by Illinois law and the Exhibitor consents to the exclusive jurisdiction of the State and Federal courts seated in Cook County, Illinois, with respect to any action arising out of this Contract or ASHRM. The parties explicitly acknowledge and agree that the provisions of this Contract are both reasonable and enforceable. However, the provisions of this Contract are severable and, as such, the invalidity of any one or more provisions shall not affect or limit the enforceability of the remaining provisions. Should any provision be held unenforceable for any reason, then such provision shall be enforced to the maximum extent permitted by law.

This Contract will be binding on the Exhibitor's heirs, successors and assigns.

32. LIMITATION OF LIABILITY

IN NO EVENT SHALL THE FACILITY, THE ASHRM EVENT, ASHRM, THEIR OWNERS, MANAGERS, OFFICERS OR DIRECTORS, AGENTS, EMPLOYEES, INDEPENDENT CONTRACTORS, SUBSIDIARIES AND AFFILIATES (COLLECTIVELY "ASHRM PARTIES") BE LIABLE TO THE EXHIBITOR OR ANY THIRD PARTY HIRED BY OR OTHERWISE ENGAGED BY THE EXHIBITOR FOR ANY LOST PROFITS OR ANY OTHER INDIRECT, SPECIAL, PUNITIVE, EXEMPLARY, INCIDENTAL OR CONSEQUENTIAL DAMAGES, INCLUDING ATTORNEY'S FEES AND COSTS, ARISING OUT OF THIS APPLICATION & CONTRACT OR CONNECTED IN ANY WAY WITH USE OF OR INABILITY TO USE THE SERVICES OUTLINED IN THIS APPLICATION & CONTRACT OR FOR ANY CLAIM BY EXHIBITOR, EVEN IF ANY OF THE ASHRM PARTIES HAVE BEEN ADVISED, ARE ON NOTICE, AND/OR SHOULD HAVE BEEN AWARE OF THE POSSIBILITY OF SUCH DAMAGES. EXHIBITOR AGREES THAT ASHRM PARTIES' SOLE AND MAXIMUM LIABILITY TO EXHIBITOR, REGARDLESS OF THE CIRCUMSTANCES, SHALL BE THE REFUND OF THE EXHIBIT BOOTH FEE. EXHIBITOR AGREES TO INDEMNIFY AND DEFEND THE ASHRM PARTIES FROM ANY CLAIMS BROUGHT BY A THIRD PARTY HIRED BY, OR ENGAGED BY THE EXHIBITOR FOR ANY AMOUNT BEYOND THE EXHIBIT BOOTH FEE. FURTHER, EXHIBITOR AGREES TO PAY ALL ATTORNEY'S FEES AND COSTS INCURRED BY ASHRM PARTIES ARISING OUT OF, OR IN ANY WAY RELATED TO, THIS CONTRACT. EXHIBITOR SHALL BE SOLELY RESPONSIBLE FOR ITS ATTORNEY'S FEES AND COSTS.

BOOTH CONSTRUCTION | DISPLAY RULES AND REGULATIONS

STANDARD INLINE BOOTH

Inline booths have only one side exposed to an aisle and are generally arranged in a series along a straight line. Individual booths may be combined to form a larger inline booth space.

Dimensions

For purposes of consistency and ease of layout, all inline booths are 10' (3.05m) across the front and 10' (3.05m) deep.

Use of Space

Regardless of the number of inline booths utilized, e.g. 10' by 20' (3.05m by 6.10m), 10' by 30' (3.05m by 9.14m), 10' by 40' (3.05m by 12.19m) etc., display materials should be arranged in such a manner as not to obstruct sight lines of neighboring Exhibitors. The maximum height of 8' (2.44m) is allowed in the rear of the booth space, with a 4' (1.22m) height restriction imposed on all materials within 5' (1.52m) of an aisle. When two (2) or more inline booths are used in combination as a single exhibit space, the 4' (1.22m) height limitation is applied only to that portion of exhibit space which is within 10' (3.05m) of an adjoining booth.

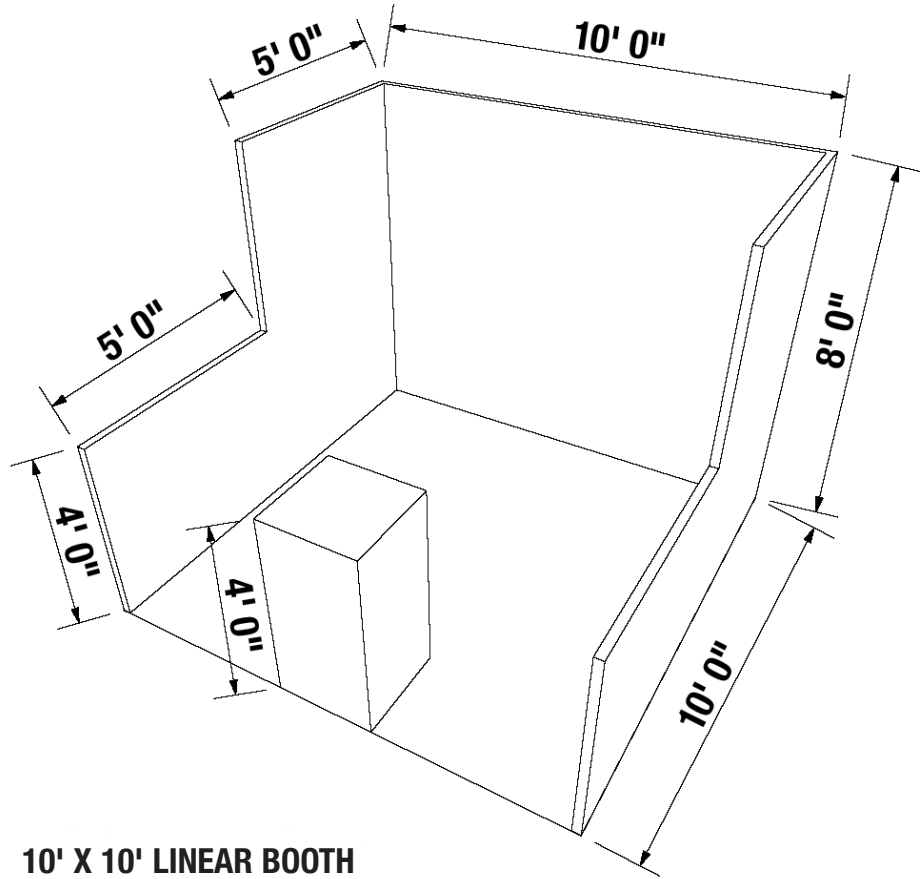

10' X 10' LINEAR BOOTH

CORNER BOOTH

A corner booth is an inline booth exposed to aisles on two (2) sides. All other guidelines for inline booths apply.

PERIMETER BOOTH

A perimeter booth is an inline booth that backs up to an outside wall of the exhibit facility rather than to another exhibit. All guidelines for inline booths apply to perimeter booths with the exception that the maximum back wall height is 12' (3.66m).

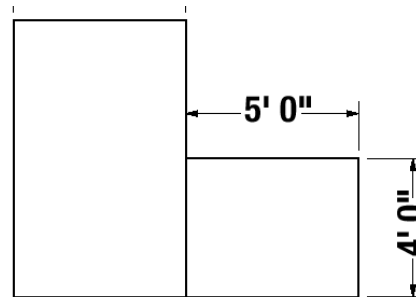

LEFT SIDE

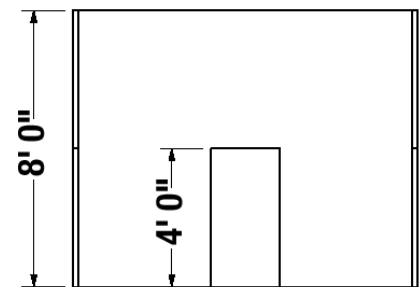

FRONT

BOOTH CONSTRUCTION | DISPLAY RULES AND REGULATIONS

PENINSULA BOOTH

A peninsula booth is exposed to aisles on three (3) sides and composed of a minimum of four (4) booths. When combining booths to create a peninsula booth, any service aisle space becomes part of the usable booth space. Backwalls must be finished and cannot contain copy. There are two (2) primary types of peninsula booths: one which backs up to inline booths and one which backs up to another peninsula booth and is referred to as a split island booth.

Dimensions

A peninsula booth is usually 20' wide (6.10m). When a peninsula booth backs up to two (2) inline booths, the backwall is restricted to 4' (1.22m) in height within 5' (1.52m) of the aisle and 10' (3.05m) of the adjoining booths. 20' (6.0m) is the maximum height allowance for the center portion of the backwall, exhibit fixtures, components and identification signs.

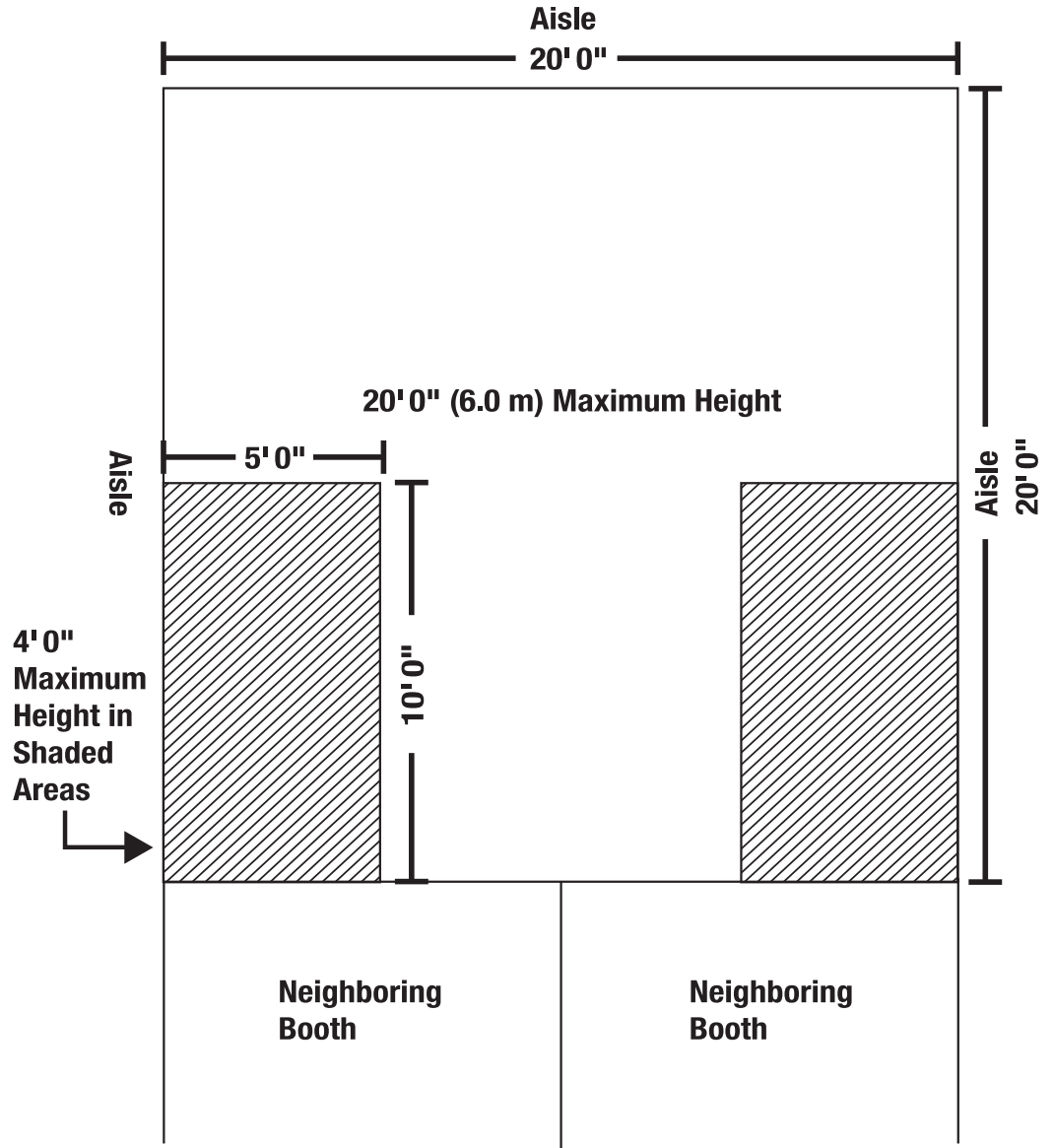

BOOTH CONSTRUCTION | DISPLAY RULES AND REGULATIONS

SPLIT ISLAND BOOTH

A split island booth is a peninsula booth that shares a common backwall with another peninsula booth. The entire cubic content of this booth may be used up to the maximum content of 20' (6.0m), including signage. Backwalls must be finished and can not contain copy.

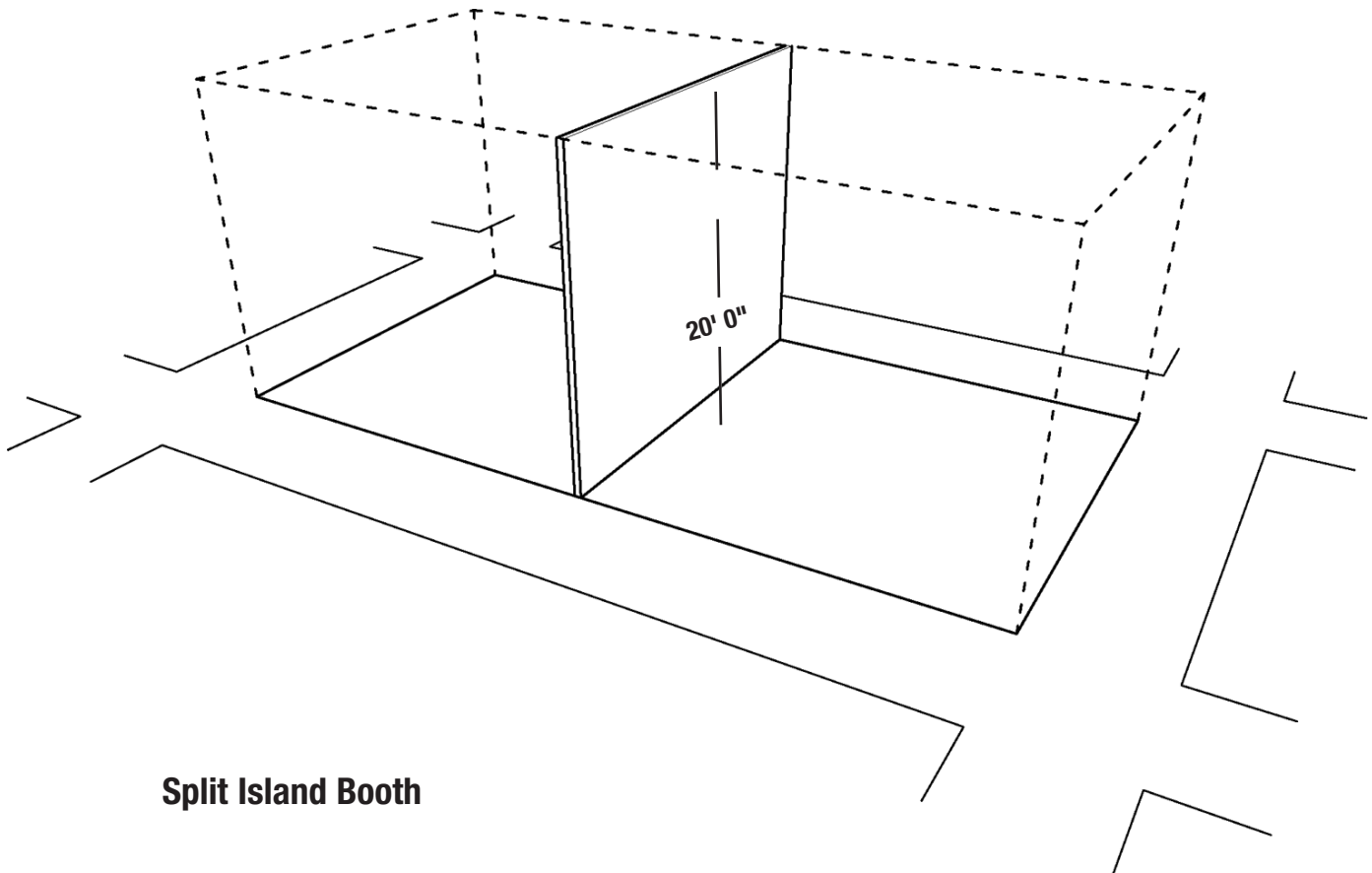

BOOTH CONSTRUCTION | DISPLAY RULES AND REGULATIONS

ISLAND BOOTH

An island booth is any size booth exposed to aisles on all four (4) sides. The entire cubic content of this booth may be used up the maximum content of 20' (6.0m), including signage.

Exhibitors may delete booths from the floor plan to form an island only, and only, if the total number of booths on both sides of the aisle totals 400 square feet or more (see diagram below).

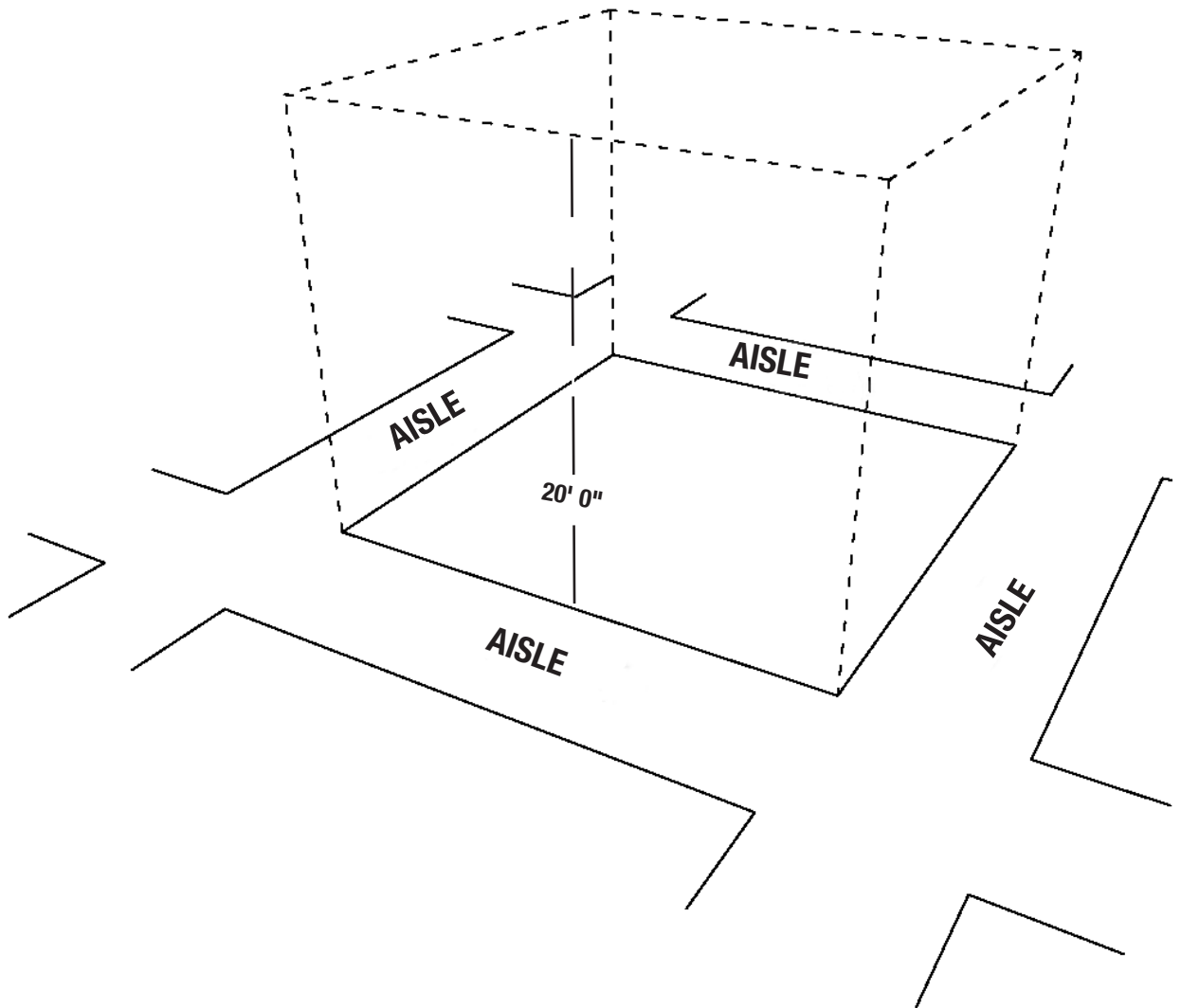

IMPORTANT BOOTH CONSTRUCTION DISPLAY CONSIDERATIONS

CANOPIES & CEILINGS

Canopies, including ceilings, umbrellas and canopy frames, can be either decorative or functional (such as to shade computer monitors from ambient light or for hanging products). Canopies for inline or perimeter booths should comply with line of sight requirements and may not protrude into the aisle.

The base of the canopy should not be lower than 7' (2.13m) from the floor within 5' (1.52m) of any aisle. Canopy supports should be no wider than 3" (7.62cm). This applies to any booth configuration that has a sightline restriction, such as an inline booth. Fire and safety regulations for the convention center may apply to canopies and ceilings and will be included in the Exhibitor Services Manual made available to Exhibitors 90 days prior to show opening. The convention center has reserved the right to update, change or amend its rules and regulations after publication in the Exhibitor Services Manual.

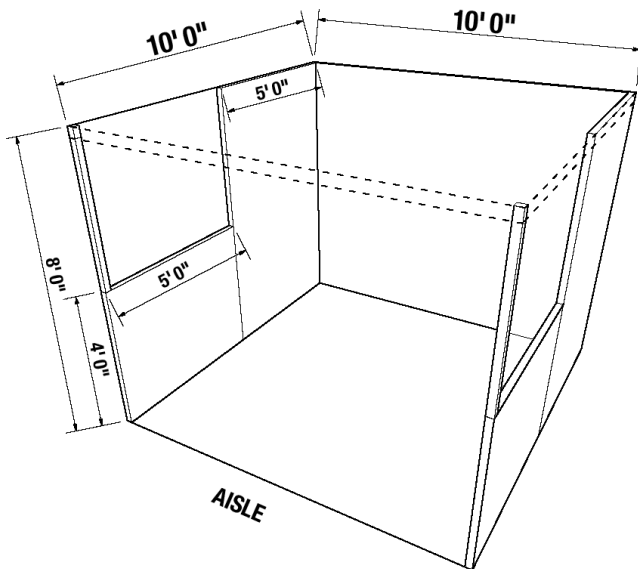

**10' X 10' INLINE BOOTH
with Canopy**

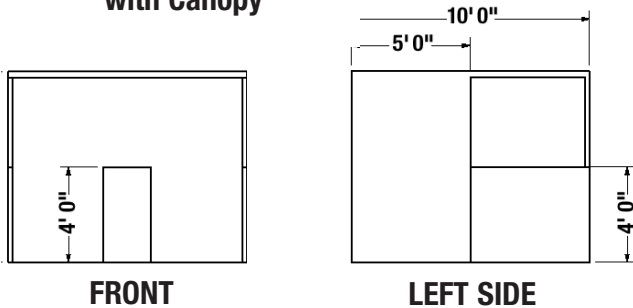

HANGING SIGNS & GRAPHICS

Hanging signs and graphics are permitted in all peninsula, modified peninsula, split island and island booths to a maximum height of 20' (6.10m) to the top of the sign. Whether suspended from above or supported from below, they should comply with all use-of-space requirements. If within 5' (1.53m) of an adjacent booth, and if the placement complies with the use-of-space requirements, the side facing the adjacent booth should be finished and not contain any copy.

MULTI-STORY EXHIBITS

A multi-story exhibit is permitted in all peninsula, modified peninsula, split island and island booths to a maximum height of 20' (6.10m). Multi-story exhibits require approval and building permits from the convention center and the fire marshal. Exhibitors should obtain permits early on to ensure that all time constraints are met. Additional information will be included in the Exhibitor Services Manual made available to Exhibitors 90 days prior to show opening.

ISSUES COMMON TO ALL BOOTH TYPES

STRUCTURAL INTEGRITY

All exhibit displays should be designed and erected in a manner that will withstand normal contact or vibration caused by neighboring Exhibitors, hall labors or installation/dismantling equipment such as fork lifts. Displays should be able to withstand moderate wind effects that may occur in the Exhibit Hall when freight doors are open. Exhibitor should ensure that any display fixtures such as tables, racks or shelves are designed and installed properly to support the product or marketing materials to be displayed upon them.

FLAMMABLE AND TOXIC MATERIALS

All materials used in display construction and decorating should be made of fire retardant materials and be certified as flame retardant. Exhibitors should dispose of any waste products they generate during the exhibition in accordance with guidelines established by the Environmental Protection Agency (EPA) and the facility.

STORAGE

Fire regulations prohibit storing product, literature, empty packing containers or packing materials behind drapes. In most cases, however, Exhibitors may store a limited supply of literature or product appropriately within the booth area, as long as these items do not impede access to utility services, create a problem or look unsightly.