



## **2026 Exhibitor Booth Space Application & Contract**

### **Contract Conditions/Rules & Regulations**

This Application & Contract to participate in the ASHE International Summit & Exhibition on Health Facility Planning, Design & Construction (“PDC Summit”) at the George R. Brown Convention Center (“Event Facility”) over March 8 - 11, 2026, including but not limited to move-in and move out dates (“Event Dates”) shall become effective when it has been submitted by the exhibiting company and accepted by the American Society for Health Care Engineering (“ASHE”). The individual signing this Application & Contract represents and warrants that he/she is duly authorized to execute this binding Application & Contract on behalf of the exhibiting company. By signing below, the exhibiting company agrees to be bound by the terms and conditions below. The exhibiting company agrees that upon acceptance of this Application & Contract by ASHE, with or without appropriate payment of the exhibition fee and further action by the exhibiting company, this Application & Contract, together with the terms and conditions below, (collectively “this Contract”) shall become a legally binding contract between ASHE and exhibiting company (“Exhibitor”).

#### **1. SHOW MANAGEMENT**

Smithbucklin will orchestrate management of Event and will be known as ASHE Show Management. Smithbucklin is responsible for assignment of exhibit booth space, exhibit logistics and collection of exhibitor payment. Smithbucklin acts as a liaison between exhibitors, ASHE and all official contractors. If you have any questions about your exhibit booth, contact Smithbucklin directly.

**Smithbucklin**  
330 N. Wabash Ave.  
Ste. 2000  
Chicago, IL 60611 USA  
Phone: 202-367-2314  
E-mail: [ASHE@smithbucklin.com](mailto:ASHE@smithbucklin.com)

#### **2. EXHIBIT BOOTH COST**

For purposes of this Application & Contract, the amount of the rental cost associated with the booth selected by Exhibitor is referred to as the “Exhibit Booth Fee.”

\$36.00/sq. ft. or \$3,600 per 10’ x 10’ booth  
\$450 corner fee

#### **3. ASSIGNMENT OF SPACE**

For all Applications & Contracts received on or before March 11, 2025, space is assigned via Onsite Space Selection during the 2025 ASHE PDC Summit at the Georgia World Congress Center on March 9 - 12, 2025.

For all Applications & Contracts received after the Onsite Space Selection is complete, space will be assigned on a first-come, first-served basis.

The priority point system outlined below will be used to assign exhibit space during Onsite Space Selection for Applications & Contracts received on or before February 20, 2025.

##### **Points:**

1 point will be awarded for each 10’ x 10’ booth space rented at each ASHE event in 2021, 2022, 2023 and 2024 and 2025 starting with the ASHE Annual Conference August 8 – 11, 2021, in Nashville, TN.

For clarity, an exhibitor who exhibits in a 10'x10' earns 1 point, an exhibitor who exhibits in a 10'x20' earns 2 points, etc.

Additional points shall be awarded to companies who have sponsored activities/functions at past ASHE Events starting with the ASHE Annual Conference August 8 – 11, 2021, in Nashville, TN, plus supported ASHE as a Corporate Sponsor/year-round sponsor and/or who advertise in ASHE's HFM magazine. Points shall be awarded based on the dollar amounts outlined below. Total points will be a cumulative score of these criteria.

**Points:**

\$5,000 – \$9,999	1 point
\$10,000 – \$14,999	2 points
\$15,000 – \$24,999	3 points
\$25,000 – \$34,999	4 points
\$35,000 – \$44,999	5 points
\$45,000 – \$54,999	6 points
\$55,000 – \$64,999	7 points
\$65,000 – \$74,999	8 points
\$75,000 – \$84,999	9 points
\$85,000 & up	10 points

There is a one-year grace period for not exhibiting. If your company does not exhibit for two consecutive years, all accumulated points are then forfeited.

If there is a priority point tie, a lottery will be held to see which company selects first. If an Exhibitor changes their name, it is their responsibility to inform ASHE Show Management. Because it is nearly impossible to contact all exhibitors for new selections of booth space, ASHE Show Management reserves the right to assign the next most suitable space when the requested space is not available. ASHE and ASHE Show Management also reserves the right, at its sole discretion, to modify the floor plan to accommodate space sales or to avoid conflicts, and, should conditions dictate, ASHE reserves the right to adjust the floor plan and relocate exhibit booths as necessary. The preferences given for booth space locations are a guidance and are not guaranteed by ASHE.

If an Exhibitor is acquired by another Exhibitor prior to the initial space selection, the Exhibitors may select booth space using the priority point status of the highest Exhibitor if exhibiting together. Priority points are not combined. If an Exhibitor is acquired by another Exhibitor after their initial space selection, the acquired Exhibitor can retain its originally contracted space, move to the acquiring Exhibitor's booth or alternatively combine booth square footage and move to a new location. Exhibitors are obligated financially for the total square footage contracted by each Exhibitor. ASHE reserves the right to require Exhibitor to provide documentation of acquisition.

All Exhibitors should frequently review their space location and changes to neighboring booths/areas for updates to the floor plan. It is the Exhibitor's responsibility to keep up with changes to their assigned area. ASHE anticipates alterations to the initial plan and cannot be held responsible for changes that may affect a participating Exhibitor's selection of space.

ASHE Show Management will maintain a waitlist for any Exhibitor who wishes to be placed in a different booth location after their initial selection. To be added to the waitlist, the Exhibitor shall submit a written request, including the requested size of space to [ASHE@smithbucklin.com](mailto:ASHE@smithbucklin.com). Exhibitors are added to the waitlist on a first-come, first-served basis based on date and time of email receipt by ASHE Show Management.

ASHE reserves the right to change Event Hours or dates, to rearrange the floor plan, and/or to relocate any Exhibitor as it deems necessary at any time.

#### **4. PAYMENTS, CANCELLATIONS & REFUNDS**

Exhibitor must remit 100% percent of their total fees within 30 days of receipt of their invoice from ASHE Show Management. Full payment must be received on or before December 1, 2025, regardless of Applications & Contract submission date. ASHE reserves the right to reassign an exhibit booth space if the Exhibitor fails to remit 100% payment by the deadline date.

Credit card payments can be made online using American Express, MasterCard or Visa. Make all checks payable to ASHE Annual Conference and remit to the following address via the U.S. Postal Service:

ASHE  
75 Remittance Drive  
Suite 1272  
Chicago, IL 60675 USA

Alternatively, Exhibitor may remit via overnight courier (e.g., FedEx) to the following address:

AHA-ASHE-91272  
5503 North Cumberland Avenue  
Chicago, IL 60656 USA

Exhibitors who wish to pay by ACH/wire must email [ASHE@smithbucklin.com](mailto:ASHE@smithbucklin.com) for remittance instructions.

ASHE reserves the right to hold or revoke Exhibitor badges for any Exhibitor with an unpaid balance and to instruct all official contractors to deny goods and services.

#### **5. CANCELLATION OF FULL OR PARTIAL SPACE BY EXHIBITOR**

Cancellation of exhibit space must be directed via email to [ASHE@smithbucklin.com](mailto:ASHE@smithbucklin.com). For cancellations of space received between the initial space selection and October 10, 2025, Exhibitor is responsible for, and ASHE shall be entitled to retain, 50 percent of the total Exhibit Booth Fee as a cancellation fee. Should an Exhibitor cancel a portion of its space between initial space selection and October 10, 2025, Exhibitor is responsible for, and ASHE shall be entitled to retain, 50 percent of the total Exhibit Booth Fee as a cancellation fee.

Full payment is required and no refunds whatsoever will be made on cancellations or reductions of space on or after October 10, 2025. Should an Exhibitor cancel even partial space on or after October 10, 2025, the Exhibitor is responsible for the full Exhibit Booth Fee for the originally contracted exhibit space.

Notwithstanding the foregoing, Exhibitor will have no right to cancel all or any portion of assigned exhibitor space or this Applications & Contract subsequent to ASHE's cancellation of the Event pursuant to Section 6.

#### **6. CANCELLATION OR CHANGES TO EVENT BY ASHE**

If for any reason beyond ASHE's control ASHE determines that the PDC Summit must be cancelled, shortened, delayed, dates changed, or otherwise altered or changed, Exhibitor understands and agrees that ASHE shall not refund the rental fees paid to it by Exhibitor and that all losses and damages that it may suffer as a consequence thereof are its responsibility and not that of ASHE or its directors, officers, employees, agents or subcontractors. Exhibitor understands that it may lose all monies it has paid to ASHE for space in the Event, as well as other costs and expenses it has incurred, including travel to the Event, setup, lodging, decorator freight, employee wages, etc.

Exhibitor, as a condition of being permitted by ASHE to be an Exhibitor in the Event, agrees to indemnify, defend and hold harmless ASHE, its directors, officer's employees, agents and subcontractors from any and all loss which Exhibitor may suffer as a result of Event cancellation, duration, delay or other alterations or changes caused in whole, or in part, by any reason outside ASHE's control. The terms of this provision shall survive the termination or expiration of this Applications & Contract.

#### **7. ELIGIBILITY TO EXHIBIT**

ASHE reserves the right to determine the eligibility of any exhibitor for inclusion in the Event and to prohibit an exhibitor from conducting and maintaining an exhibit if, in the sole judgment of ASHE, the exhibitor or exhibit or proposed exhibit shall in any respect be deemed unsuitable. An Exhibitor's eligibility to exhibit in the Event must remain in effect from the time of submission of the Application & Contract to the time of the Event and should ASHE determine that an Exhibitor which it had previously determined was eligible to exhibit at the Event is no longer eligible to do so, ASHE may notify the Exhibitor and may terminate the Application & Contract without liability upon written notice to Exhibitor. Exhibitors are prohibited from assigning or subletting a booth or any part of the space allotted to

them nor shall they exhibit or permit to be exhibited in their space any products or advertising materials for other companies.

#### **8. SUBLETTING OF EXHIBIT SPACE PROHIBITED**

Exhibitors are prohibited from assigning or subletting a booth or any part of the space allotted to them nor shall they exhibit or permit to be exhibited in their space any products or advertising materials which are not a part of their own regular products, or which are not compatible with the purpose and/or character of the ASHE Annual Conference as determined by ASHE in its sole discretion.

#### **9. PROMOTIONAL ACTIVITIES**

Further, Exhibitors shall not engage in any promotional activities which ASHE determines to be outside the purpose and/or character of the ASHE PDC Summit as determined by ASHE in its sole discretion.

#### **10. RETAIL SALES**

No retail sales, where payment is received and product delivered, are permitted during the Event at any time. Payment and/or orders may be taken for future delivery.

#### **11. INTELLECTUAL PROPERTY MATTERS**

The Exhibitor represents and warrants to ASHE that no materials used in or in connection with their exhibit infringe the trademarks, copyrights (including, without limitation, copyrights in music and other materials used or broadcast by Exhibitor) or other intellectual property rights of any third party. The Exhibitor agrees to immediately notify ASHE of any information of which the Exhibitor becomes aware regarding actual or alleged infringement of any third party's trademarks, copyrights or other intellectual property rights. The Exhibitor agrees to indemnify, defend and hold ASHE, its officers, directors, employees, agents, successors and assigns harmless from and against all losses, damages and costs (including attorney's fees) arising out of or related to claims of infringement by Exhibitor, its employees, agents, or contractors of the trademarks, copyrights and other intellectual property rights of any third party.

Notwithstanding the foregoing, ASHE, its officers, directors, employees, agents, and each of them, shall not be liable for and expressly disclaims all liability for infringement or alleged infringement of the trademarks, copyrights or other intellectual property of any third party arising out of the actions of any Exhibitors. The terms of this provision shall survive the termination or expiration of this Contract.

#### **12. USE OF ASHE NAME**

ASHE, ASHE PDC Summit and Event logo are registered trademarks owned by the ASHE. Participation by an Exhibitor in the Event does not entitle the Exhibitor to use such names or logos, except that the Exhibitor may reference the ASHE PDC Summit and use the Event logo with reference to the Exhibitor's participation as an Exhibitor at the ASHE PDC Summit. Participation in the Event does not imply endorsement or approval by ASHE of any product, service or participant and none shall be claimed by any participant.

#### **13. SET-UP TIME**

Set-up of exhibits begins in the Facility at 8:00 AM, Saturday, March 7. If an exhibit is not set-up by 8:30 AM, Monday, March 9, ASHE reserves the right to cancel such space, to re-assign such space to another Exhibitor, or to make such other use of the space as deemed necessary or appropriate. ASHE reserves the right to set-up the exhibit or remove the freight from the booth at the Exhibitor's expense. No refund will be made to the original contracting Exhibitor. ASHE reserves the right to modify move-in/move-out/Event Hours, in which case all Exhibitors will be notified prior to the effective date of such changes.

#### **14. EXHIBIT HOURS**

Monday, March 9  
9:45 AM-2:00 PM  
4:45 PM-6:30 PM

Tuesday, March 10  
9:30 AM-2:00 PM

ASHE reserves the right to change the Exhibit Hours listed above.

## 15. DISMANTLING OF EXHIBITS

Exhibits are to be kept intact until the closing of the Event at 2:00 PM on Tuesday, March 10. No part of an exhibit shall be removed during the Event without special permission from ASHE Show Management. Any Exhibitor who begins dismantling of its booth before the close of the Event may lose part or all of their priority points and may entirely lose the privilege of exhibiting at future ASHE events.

All carriers must check-in by 10:00 AM on Wednesday, March 11. All freight must be removed from Facility by 12:00 PM, Wednesday, March 11. If exhibits are not removed by this time, ASHE reserves the right to remove exhibits and charge the expense to the Exhibitor and ASHE shall have no liability for any loss or damage to Exhibitor's exhibit property caused by such removal.

## 16. BADGES

Exhibitors are provided (3) complimentary Exhibit Hall badges and (1) complimentary Full Conference badge for the first 100 sq. ft. of exhibit space purchased. Exhibitors are provided (4) additional complimentary Exhibit Hall badges and 1 complimentary Full Conference badge for every additional 100 sq. ft. of exhibit space purchased. Additional Exhibit Hall badges are \$210 each and Full Conference badges are \$925 each. See grid for badge allotment per booth square footage:

<b>Square Feet</b>	<b>Complimentary Booth Badge Allotment</b>
100 sq. ft.	(3) Exhibit Hall; (1) Full Conference
200 sq. ft.	(7) Exhibit Hall; (2) Full Conference
300 sq. ft.	(11) Exhibit Hall; (3) Full Conference
400+ sq. ft.	(15) Exhibit Hall; (4) Full Conference

All Exhibitor badges are for Exhibitor's full and part time employees or contractors. Exhibitor badges allow access to the Exhibit Hall during the following move-in, Event and move-out hours:

Saturday, March 7 (Set-up)  
8:00 AM-4:30 PM

Sunday, March 8 (Set-up)  
8:00 AM-4:30 PM

Monday, March 9 (Set-up & Event Day 1)  
7:00 AM-6:30 PM

Tuesday, March 10 (Event Day 2 & Dismantle)  
9:00 AM-8:00 PM

Wednesday, March 11 (Dismantle)  
8:00 AM-12:00 PM

ASHE reserves the right to change the access times listed above.

Event attendees do not have access to the Exhibit Hall until Monday, March 9 at 9:45 AM. Exhibitors who give their badges to an Event attendee in order for the attendee to gain access to the Exhibit Hall prior to this time may, at the sole discretion of ASHE, lose part or all of its company's priority points, and may entirely lose the privilege of exhibiting in future ASHE events. ASHE reserves the right to give an Exhibit Hall pass to any Exhibitor or Event attendee in order to grant them access to the Exhibit Hall at any time.

## 17. MINIMUM AGE FOR ADMISSION

Children under the age of 16 are not permitted in the Exhibit Hall at any time. Any attendees arriving with children under the age of 16 will be denied access to the Exhibit Hall with such children without any exceptions or refunds.

## 18. EXHIBITOR LIABILITY

Exhibitor remains solely responsible for the safety of its property at all times during transit to and from the Facility and in the Exhibit Hall. Neither ASHE, its directors, officers, employees, agents, subcontractors nor ASHE Show Management (collectively "Event Management") are responsible for Exhibitor's property or any loss thereto from any cause.

EXHIBITOR HEREBY WAIVES AND RELEASES ANY CLAIM OR DEMAND IT MAY HAVE AGAINST ANY OF THE EVENT MANAGEMENT BY REASON OF ANY DAMAGE TO OR LOSS OF ANY OF ITS PROPERTY.

## 19. INDEMNIFICATION

Exhibitor agrees that it will indemnify, defend and hold Event Management, ASHE, their respective officers, directors, employees, agents and each of them, harmless from and against a) the performance or breach of this Contract by Exhibitor, its employees, agents or contractors; b) the failure by Exhibitor, its employees, agents or contractors to comply with applicable laws, regulations and ordinances; and c) the act, omission, negligence, gross negligence, or willful misconduct of Exhibitor, its employees, agents, contractors, licensees, guests, or invitees. This indemnification of Event Management by Exhibitor is effective unless such injury was caused by the sole gross negligence or willful misconduct of Event Management. Exhibitor agrees that if Event Management or ASHE is made a party to any litigation commenced by or against Exhibitor, or relating to this Contract or the premises leased hereunder, then EXHIBITOR WILL PAY ALL COSTS AND EXPENSES, including attorneys' fees, INCURRED BY OR IMPOSED UPON EVENT MANAGEMENT OR ASHE BY REASON OF SUCH LITIGATION. THE TERMS OF THIS PROVISION SHALL SURVIVE THE TERMINATION OR EXPIRATION OF THIS CONTRACT.

## 20. INSURANCE

Exhibitors are required to maintain and to provide a certificate of insurance to ASHE Show Management on or before February 6, 2026, evidencing the following:

- (a) General liability with limits not less than \$1,000,000 per occurrence, \$2,000,000 in the aggregate
- (b) Owned (if applicable), hired and non-owned auto liability with limits not less than \$1,000,000 per occurrence
- (c) Workers' compensation with state statutory limits
- (d) Employer's liability with limits not less than \$500,000
- (e) Commercial umbrella liability with limits not less than \$1,000,000
- (f) Personal property and equipment on a special form replacement cost basis

ASHE, Smithbucklin Corporation and the George R. Brown Convention Center are to be listed as additional insureds on a primary and non-contributory basis with respect to general/auto/umbrella liability.

A waiver of subrogation must apply to all policies. All carriers are to maintain an A.M. Best rating of not less than A-VII.

Exhibitors will not be permitted to set up their booth without submitting the proper certificates. Certificates should be emailed to [ASHE@smithbucklin.com](mailto:ASHE@smithbucklin.com) or mailed to:

ASHE Show Management  
C/O Smithbucklin  
330 N. Wabash Ave.  
Ste. 2000  
Chicago, IL 60611 USA

## 21. USE OF SPACE — GENERAL

- (a) No Exhibitor is permitted to display or distribute literature or any promotion outside the confines of the assigned exhibit space in the Exhibit Hall. Distribution or display of promotional material in public areas of the Facility or meeting rooms is strictly prohibited. ASHE also reserves the right to remove, at Exhibitor's cost, any promotional material or product deemed by Event Management as not suitable for display at the ASHE PDC Summit.

- (b) Exhibitors are prohibited from possessing, displaying or depicting any products or components or company names in their booth that could be interpreted as being a promotion or comparison (features, benefits, price) of another company.
- (c) No exhibit will be permitted that interferes with the use of other exhibits or impedes access to them or impedes the free use of the aisles.
- (d) Distribution by Exhibitors, or their agents, of any printed materials, souvenirs or other articles shall be restricted to the Exhibitor's exhibit space. No noisemakers, helium balloons, lighter-than-air objects, gummed stickers, popcorn, or labels will be permitted as handouts.
- (e) Any special promotions, music or stunts planned for the Exhibit Hall, must be approved with ASHE. Details should be submitted to ASHE Show Management via email to [ASHE@smithbucklin.com](mailto:ASHE@smithbucklin.com) at least 10 business days prior to the start of the Event. ASHE reserves the right to designate specific days and hours during which special promotions and stunts may be conducted, if they are permitted at all.
- (f) ASHE allows drawings, games of chance and raffles on the Exhibit Hall, subject to the prior written approval of ASHE. Exhibitors must abide by all Houston/Harris County/Texas statutes and regulations regarding drawings, games of chance and raffles. Exhibitors should send their approval requests to ASHE Show Management via email to [ASHE@smithbucklin.com](mailto:ASHE@smithbucklin.com).
- (g) No animals are permitted in the Facility other than service animals.
- (h) Exhibitors must abide by all of the General Policies, Rules, and Regulations of the Facility, a copy of which is included in the Exhibitor Services Manual, made available to Exhibitors in October. The Facility has reserved the right to update, change or amend its rules and regulations after publication in the Exhibitor Services Manual. To obtain a copy of the General Policies, Rules, and Regulations of the Facility prior to publication in the Exhibitor Services Manual Exhibitor may email [ASHE@smithbucklin.com](mailto:ASHE@smithbucklin.com).
- (i) ASHE Show Management shall publish health and safety guidelines for COVID based on CDC recommendations in the Exhibitor Services Manual. Exhibitor agrees to abide by the guidelines. ASHE reserves the right to update, change or amend the guidelines after publication in the Exhibitor Services Manual.
- (j) All Exhibitors shall be responsible for compliance with the Americans with Disabilities Act. The Exhibitor shall indemnify, defend and hold Event Management harmless from any and all claims, costs, expenses or other damages, arising out of Exhibitor's breach of this provision consequences of Exhibitor's failure in this regard. The terms of this provision shall survive the termination or expiration of this Contract. For more information on the Americans with Disabilities Act and how to make your exhibit accessible to persons with disabilities, please contact:
  - U.S. Department of Justice ADA, Civil Rights Division Disability Rights Section – NYAV
  - 950 Pennsylvania Avenue, NW
  - Washington, D.C. 20530 USA
  - Phone: 800.514.0301 (voice) 800.514.0383 (TTY)
  - [www.ada.gov](http://www.ada.gov)
- (k) Any Exhibitor occupying an Island, Split Island, Peninsula or Modified Peninsula space is required to submit a detailed floor plan, including dimensions, to ASHE Show Management for review and approval by February 6, 2026. All Exhibitors who received a written booth violation notice at the 2025 ASHE Health Care Facilities Innovation Conference or 2025 ASHE PDC Summit are required to submit a detailed floor plan, including dimensions, to ASHE Show Management for review and approval by February 6, 2026. Exhibitors who receive two or more written booth violations in the last two years may, at the sole discretion of ASHE, lose part or all of its company's priority points, and may entirely lose the privilege of exhibiting in future ASHE events. Floor plans should be submitted via email to [ASHE@smithbucklin.com](mailto:ASHE@smithbucklin.com).
- (l) Umbrellas and canopies are considered part of the overall booth components and may not protrude into the aisle.
- (m) The use of flammable or volatile materials is prohibited unless approved in advance and in writing by the fire marshal and General Manager. Non-flammable compressed gas tanks must be properly secured to prevent toppling. Facility reserves the right to require compressed gas tanks to be removed from the Exhibit Hall during Event Hours. Helium-filled balloons are not allowed in the Facility. Balloons may not be given out within the Facility. All lighter-than-air objects are not allowed in the Facility. Both the ASHE and Facility reserve the right to assess a fee for retrieving any escaped lighter-than-air objects to the Exhibitor.

- (n) Key Bookings is the Event only official housing vendor and other companies may not provide the prices, service and reliability available from Key Bookings. Each exhibitor will receive an email with a secure link to reserve housing after completing their exhibitor badge registration. If Exhibitor is contacted by ANY company except Key Bookings about hotel reservations for ASHE PDC Summit, please inform ASHE Show Management. ASHE shall not be responsible for any damages or costs related to Exhibitor making hotel reservations via an unauthorized solicitation of hotel reservations.
- (o) All booth personnel must be properly and modestly clothed.
- (p) Exhibitors are permitted to serve food and non-alcoholic beverages in their booth during Event Hours. Non-alcoholic beverages do not need to be served by a bartender but all beverages and food must be ordered through the Facility's caterer.
- (q) Exhibitors are permitted to provide alcoholic beverages in their booth by contracting a Bar or Specialty Cocktail Sponsorship, contact ASHE Show Management at [ASHE@smithbucklin.com](mailto:ASHE@smithbucklin.com) at least 30 business days prior to the start of the Event for review and approval. Alcoholic beverages served in booths may only be purchased and served by licensed bartenders from the Facility's Food and Beverage Department and must be ordered through the Facility's caterer.
- (r) Levy of the George R. Brown Convention Center is the official in-house caterer and is the exclusive provider of food and/or beverage items at the Facility. If requested, Levy may allow Exhibitors to bring their own food and/or beverage into the Facility for the sole purpose of equipment demonstration, provided the Exhibitor has signed and submitted a sampling and waiver form to Levy which can be found in the Exhibitor Services Manual or by emailing [ASHE@smithbucklin.com](mailto:ASHE@smithbucklin.com). If Levy is required to handle, store, refrigerate, transport, deliver, prepare, or service any of the demonstration food and beverage product brought in by the Exhibitor, charges will apply. Only food and/or beverages used for Exhibitor's equipment demonstration will be permitted.
- (s) Exhibitors, at ASHE's sole discretion, are prohibited from taking videos and photographs of any booths in the Exhibit Hall, other than their own. Aerial photography, videography or stunts of any kind by an Exhibitor, i.e. drones, are strictly prohibited. The Exhibitor acknowledges and agrees that ASHE, its employees and contractors may take photographs/videos which could include images of the Exhibitor, its name and logo, its representatives and its exhibits while attending the Exhibition. The Exhibitor hereby consents to and grants to the ASHE and its affiliates, the unrestricted, perpetual, worldwide, royalty-free and transferable right and license to use (and grant others the right to use) the images worldwide without any compensation. The Exhibitor acknowledges that ASHE is the sole and exclusive owner of all rights in the images and hereby waives (a) any and all rights in and to such images, and (b) any and all claims the Exhibitor and its representatives may have relating to or arising from the images or their use.
- (t) Music in the booth or at any of Exhibitor's function held in conjunction with ASHE PDC Summit is subject to applicable copyright and licensing fees. It is the sole responsibility of the Exhibitor to pay applicable fees.
- (u) Hanging signs are permitted in all peninsulas, modified peninsulas, split islands and island booths to a maximum height of (20') (6.10 m) to the top of the sign. Hanging signs are NOT permitted in inline booths including perimeter booths.
- (v) All exhibit fixtures and booth structures are permitted to a maximum height of (8') (2.44 m) in inline booths. All exhibit fixtures and booth structures are permitted to a maximum height of (12') (3.66 m) in all perimeter booths. All exhibit fixtures and booth structures are permitted to a maximum height of (20') (6.10 m) in all peninsulas, modified peninsulas, split islands and island booths. Exhibitor agrees to abide by these maximum height limits and all other Booth Construction/Display Rules & Regulations, see Appendix.
- (w) In order to ensure the success of the Event and avoid dilution of benefits extended to all partners, Exhibitor may not extend invitations, call meetings or otherwise encourage absence of other exhibitor's/sponsors attendees from any program or other component of the Event during the official hours of the Event or any function sponsored in connect with the Event by ASHE without prior notice to and approval by ASHE.

## 22. USE OF SPACE — LIGHTS/ AUDIO, ETC.

- (a) No spotlight may be directed toward the aisles or so directed that it proves to be irritating or distracting to neighboring Exhibitors or guests.
- (b) Droplights or special lighting devices must be hung at a level or positioned so as not to prove to be an irritant or distraction to neighboring Exhibitors or guests.
- (c) No strobe light effects are permitted.

- (d) Projectors, computer screens or TV screens must not cause people to block the aisle. Computer screens and TV screens are considered part of the overall booth components and may not protrude into the aisle.
- (e) Loud speakers or operation of equipment, which is of excessive sound volume to be annoying to neighboring Exhibitors or guests is not permitted based on the 80/80 Rule: Any sound that consistently exceeds 80 decibels measured at the edge of an Exhibitor's booth or is clearly identifiable more than 80 feet from that booth is considered objectionable.
- (f) No lighting, fixtures, lighting trusses, or overhead lighting are allowed outside the boundaries of the exhibit space. All lighting should be directed to the inner confines of the booth space. Lighting should not project onto other exhibits or aisles. Exhibitors intending to use hanging light systems are required to submit a detailed floor plan with light locations and dimensions, including height, of all items in the booth, to Event Management for review and approval by February 6, 2026.
- (g) Vehicles may not be displayed without prior written approval from ASHE and the Facility Public Safety Department.

### **23. DISPLAYS OUTSIDE EXHIBIT AREA**

Absolutely no exhibits are permitted outside the Facility. There are to be no displays in hotel rooms, hotel public areas or other facilities or areas contracted or used by ASHE.

### **24. HOTEL ROOMS, SUITES & MEETING ROOMS**

ASHE reserves the right to control all suites and meeting rooms in the Facility and in those hotels participating in the ASHE housing block. These controls have already been set up with each property. The Meeting Space Request Form should be used to submit requests for function space, including meeting and hospitality rooms. You may submit your application for meeting space online on the 'Exhibitor Resource' page of the website. No meetings, private functions, including lunch meetings, or entertainment can be scheduled during Event Hours (8:00 AM - 6:30 PM on Monday, March 9, 8:00 AM – 5:00 PM on Tuesday, March 10; 8:00 AM – 12:00 PM on Wednesday, March 11). No product displays or demonstrations are permitted in meeting rooms. Activities that conflict with the nature of the ASHE PDC Summit are not permitted. Suites and meeting rooms are assigned on a first-come, first-served basis and only to Exhibitors and organizations allied with ASHE.

### **25. ATTENDEE LISTS**

Attendee lists from the Event are distributed only to exhibiting companies, other official partners and attendees. Please note that no other individual or organization is authorized to market or to sell attendee lists of ASHE. Such lists shall only be used for a (1) time mailing of promotional material relating to Exhibitor's booth at the Event and shall not be reproduced, transferred or used in any other manner. In using such lists for mailings, Exhibitors must ensure compliance with all country, state and local laws and regulations including, but not limited to, the European Union's General Data Protection Regulations (GDPR) and the California Consumer Privacy Act (CCPA). The Exhibitor shall indemnify, hold ASHE, its directors, officers, employees, agents or subcontractors harmless from the performance or breach of this provision by Exhibitor, its employees, agents or contractors. The terms of this provision shall survive the termination or expiration of this Contract.

### **26. FIRE REGULATIONS**

- (a) All materials used in exhibit booth(s) must be of a non-flammable nature. Electric signs and equipment must be wired to meet the specifications of the Facility and the Fire Marshal.
- (b) Any Exhibitor having equipment that produces heat, smoke or open flames as an integral part of product demonstration must provide ventilation, safety equipment and proper insulation and utility connections meeting all local fire regulations. Such Exhibitors must receive written approval of plans from the Facility and from ASHE.
- (c) Exhibitor agrees to abide by the National Fire Protection Association. Basic Fire Code Regulations: The National Fire Protection Association (NFPA) 101 Life Safety Code 1997 that has been adopted with specific revisions by the Facility. Reference copies of the fire code are available from George R. Brown Convention Center. Exhibitor can request a copy via email by emailing [ASHE@smithbucklin.com](mailto:ASHE@smithbucklin.com).

### **27. LABOR RELATIONS**

- (a) Full-time employees of exhibiting companies may set up their own exhibits without the use of power tools or ladders. Any labor services that may be required beyond what your regular full-time employees can provide must be rendered by union personnel and can be ordered in advance through The Expo Group. Proof of full-time employment status may be requested by the Union Steward of any personnel working in your booth.
- (b) Exhibitors may hand carry their own materials into the exhibit facility. The use or rental of flat trucks and other mechanical equipment, however, is not permitted. The Expo Group controls access to the loading docks in order to provide for a safe and orderly move-in/out. Only full-time employees of the exhibiting company are allowed to hand carry items. Unloading or reloading at the dock of any and all contracted carriers will be handled by The Expo Group.
- (c) If Exhibitors intend to use an Exhibitor Appointed Contractor (EAC) to install and/or dismantle their booth, the Exhibitor must register their EAC no later than February 10, 2025. An EAC registration form is provided in the Exhibitor Services Manual. An original Certificate of Insurance must be filed with ASHE in order for any EACs to gain access to the Exhibit Hall. All EACs are required to wear both a Facility Access Credential and individual event credentials at all times.
- (d) The Facility and The Expo Group have reserved the right to update, change or amend the labor rules and/or labor credential process outlined above. ASHE shall inform all Exhibitors of any changes or amendments.

## **28. EXHIBITOR SERVICES MANUAL**

In October, The Expo Group distributes an Exhibitor Services Manual to each Exhibitor that provides Exhibitors with complete shipping instructions, production information, and other forms for all services needed during set-up, Event Hours and dismantle. The Expo Group discount deadline is February 10, 2025.

## **29. WARRANTIES**

ASHE makes no warranties, either express or implied, as to the availability or suitability of the contractors, services and/or equipment of the Facility, ASHE, or their respective employees, agents or contractors.

## **30. AMENDMENTS/ INTERPRETATION**

ASHE reserves the right to amend and enforce this Contract. Written notice of any amendments shall be given to each affected Exhibitor. Each Exhibitor, for itself, its agents and employees, agrees to abide by this Contract set forth therein, or by any subsequent amendments. ASHE reserves the sole right to interpret this Contract. All interpretations are final and are not subject to review or to appeal. Exhibitors which, in the sole interpretation of ASHE shall be subject to disciplinary action up to and including ejection from the Event and refusal to participate in any future events or Events of ASHE.

## **31. ENFORCEMENT/ MISCELLANEOUS**

This Contract is governed by Illinois law and the Exhibitor consents to the exclusive jurisdiction of the State and Federal courts seated in Cook County, Illinois, with respect to any action arising out of this Contract or ASHE. The parties explicitly acknowledge and agree that the provisions of this Contract are both reasonable and enforceable. However, the provisions of this Contract are severable and, as such, the invalidity of any one or more provisions shall not affect or limit the enforceability of the remaining provisions. Should any provision be held unenforceable for any reason, then such provision shall be enforced to the maximum extent permitted by law.

This Contract will be binding on the Exhibitor's heirs, successors and assigns.

## **32. LIMITATION OF LIABILITY**

IN NO EVENT SHALL THE FACILITY, THE ASHE PDC SUMMIT, ASHE , THEIR OWNERS, MANAGERS, OFFICERS OR DIRECTORS, AGENTS, EMPLOYEES, INDEPENDENT CONTRACTORS, SUBSIDIARIES AND AFFILIATES (COLLECTIVELY "ASHE PARTIES") BE LIABLE TO THE EXHIBITOR OR ANY THIRD PARTY HIRED BY OR OTHERWISE ENGAGED BY THE EXHIBITOR FOR ANY LOST PROFITS OR ANY OTHER INDIRECT, SPECIAL, PUNITIVE, EXEMPLARY, INCIDENTAL OR CONSEQUENTIAL DAMAGES, INCLUDING ATTORNEY'S FEES AND COSTS, ARISING OUT OF THIS APPLICATION & CONTRACT OR CONNECTED IN ANY WAY WITH USE OF OR INABILITY TO USE THE SERVICES OUTLINED IN THIS

APPLICATION & CONTRACT OR FOR ANY CLAIM BY EXHIBITOR, EVEN IF ANY OF THE ASHE PARTIES HAVE BEEN ADVISED, ARE ON NOTICE, AND/OR SHOULD HAVE BEEN AWARE OF THE POSSIBILITY OF SUCH DAMAGES. EXHIBITOR AGREES THAT ASHE PARTIES' SOLE AND MAXIMUM LIABILITY TO EXHIBITOR, REGARDLESS OF THE CIRCUMSTANCES, SHALL BE THE REFUND OF THE EXHIBIT BOOTH FEE. EXHIBITOR AGREES TO INDEMNIFY AND DEFEND THE ASHE PARTIES FROM ANY CLAIMS BROUGHT BY A THIRD PARTY HIRED BY, OR ENGAGED BY THE EXHIBITOR FOR ANY AMOUNT BEYOND THE EXHIBIT BOOTH FEE. FURTHER, EXHIBITOR AGREES TO PAY ALL ATTORNEY'S FEES AND COSTS INCURRED BY ASHE PARTIES ARISING OUT OF, OR IN ANY WAY RELATED TO, THIS CONTRACT. EXHIBITOR SHALL BE SOLEY RESPONSIBLE FOR ITS ATTORNEY'S FEES AND COSTS.

## BOOTH CONSTRUCTION | DISPLAY RULES AND REGULATIONS

### STANDARD INLINE BOOTH

Inline booths have only one side exposed to an aisle and are generally arranged in a series along a straight line. Individual booths may be combined to form a larger inline booth space.

#### Dimensions

For purposes of consistency and ease of layout, all inline booths are 10' (3.05m) across the front and 10' (3.05m) deep.

#### Use of Space

Regardless of the number of inline booths utilized, e.g. 10' by 20' (3.05m by 6.10m), 10' by 30' (3.05m by 9.14m), 10' by 40' (3.05m by 12.19m) etc., display materials should be arranged in such a manner as not to obstruct sight lines of neighboring Exhibitors. The maximum height of 8' (2.44m) is allowed in the rear of the booth space, with a 4' (1.22m) height restriction imposed on all materials within 5' (1.52m) of an aisle. When two (2) or more inline booths are used in combination as a single exhibit space, the 4' (1.22m) height limitation is applied only to that portion of exhibit space which is within 10' (3.05m) of an adjoining booth.

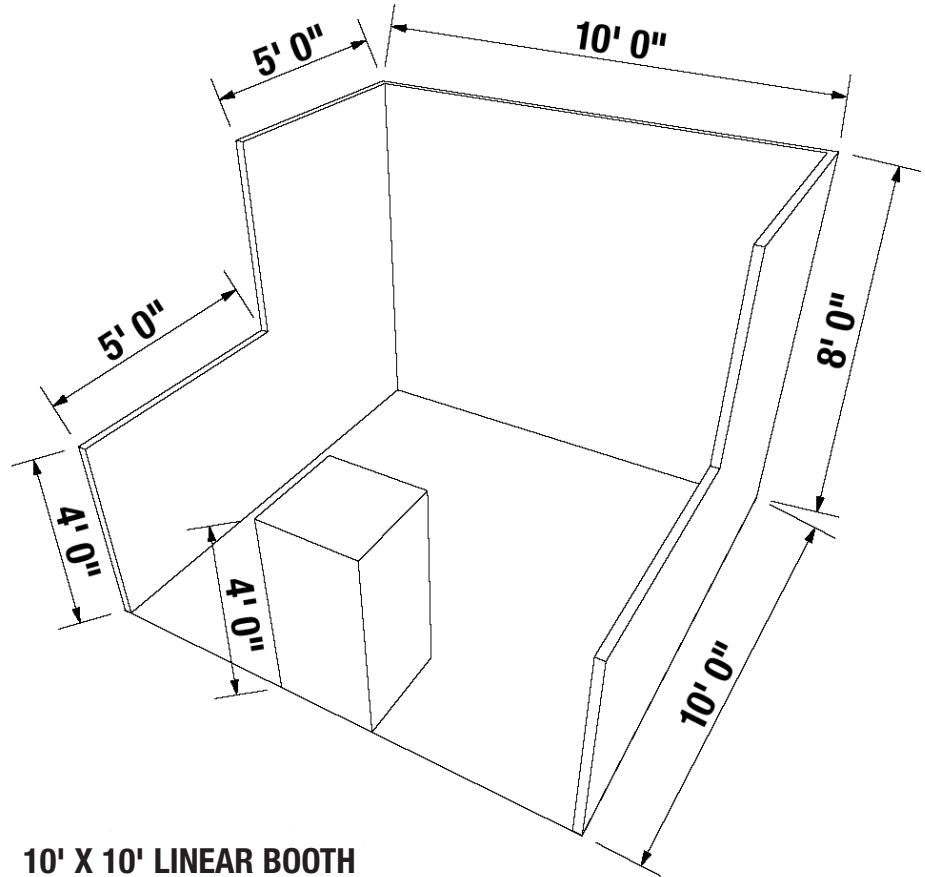

10' X 10' LINEAR BOOTH

### CORNER BOOTH

A corner booth is an inline booth exposed to aisles on two (2) sides. All other guidelines for inline booths apply.

### PERIMETER BOOTH

A perimeter booth is an inline booth that backs up to an outside wall of the exhibit facility rather than to another exhibit. All guidelines for inline booths apply to perimeter booths with the exception that the maximum back wall height is 12' (3.66m).

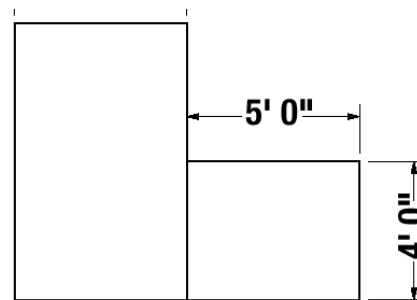

LEFT SIDE

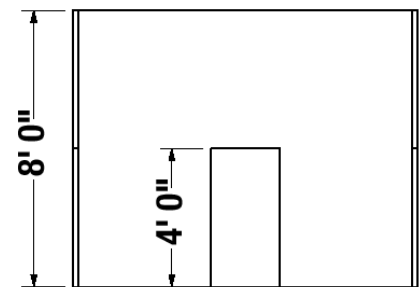

FRONT

## BOOTH CONSTRUCTION | DISPLAY RULES AND REGULATIONS

### PENINSULA BOOTH

A peninsula booth is exposed to aisles on three (3) sides and composed of a minimum of four (4) booths. When combining booths to create a peninsula booth, any service aisle space becomes part of the usable booth space. Backwalls must be finished and cannot contain copy. There are two (2) primary types of peninsula booths: one which backs up to inline booths and one which backs up to another peninsula booth and is referred to as a split island booth.

#### Dimensions

A peninsula booth is usually 20' wide (6.10m). When a peninsula booth backs up to two (2) inline booths, the backwall is restricted to 4' (1.22m) in height within 5' (1.52m) of the aisle and 10' (3.05m) of the adjoining booths. 20' (6.0m) is the maximum height allowance for the center portion of the backwall, exhibit fixtures, components and identification signs.

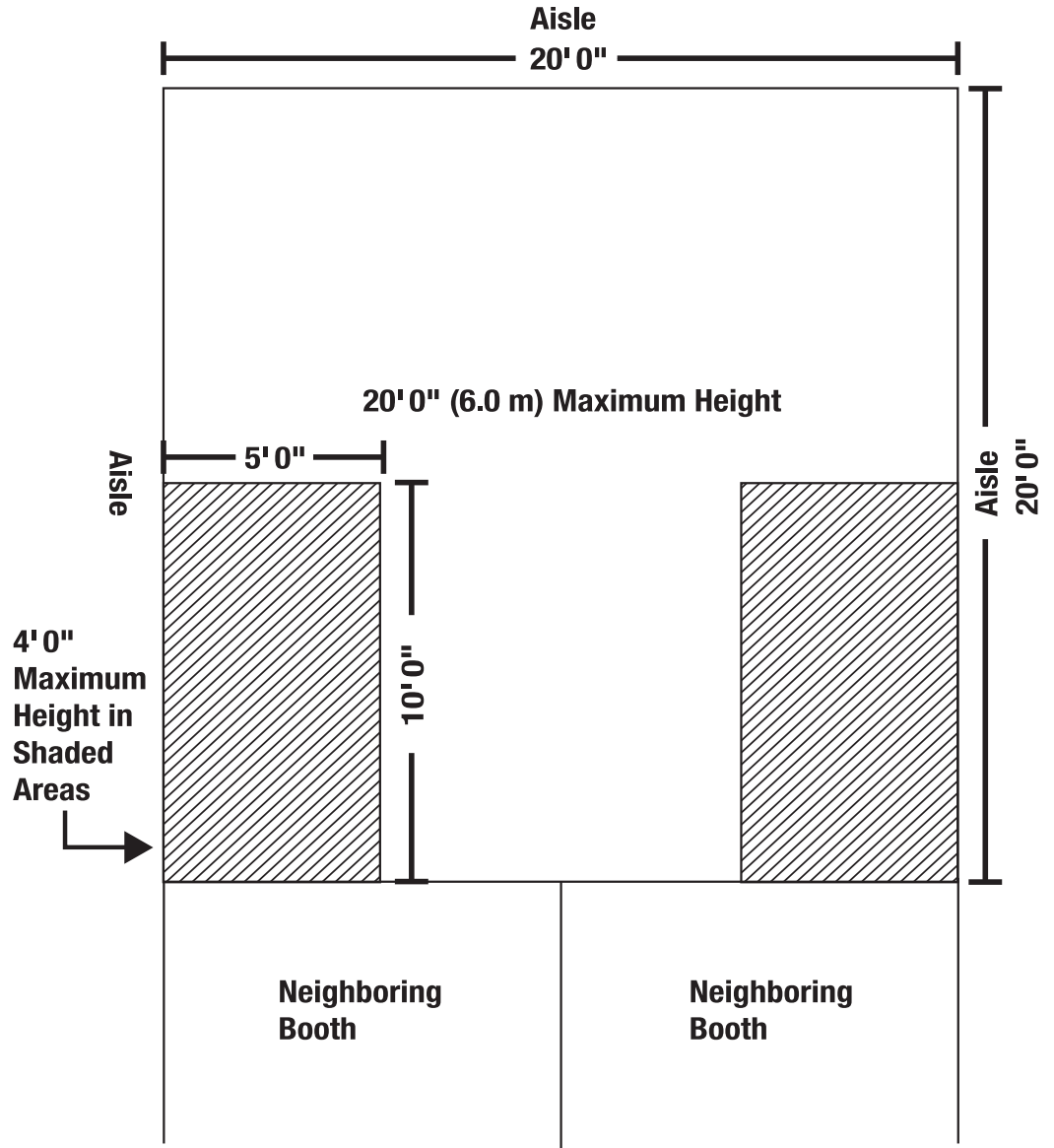

## BOOTH CONSTRUCTION | DISPLAY RULES AND REGULATIONS

### **SPLIT ISLAND BOOTH**

A split island booth is a peninsula booth that shares a common backwall with another peninsula booth. The entire cubic content of this booth may be used up to the maximum content of 20' (6.0m), including signage. Backwalls must be finished and can not contain copy.

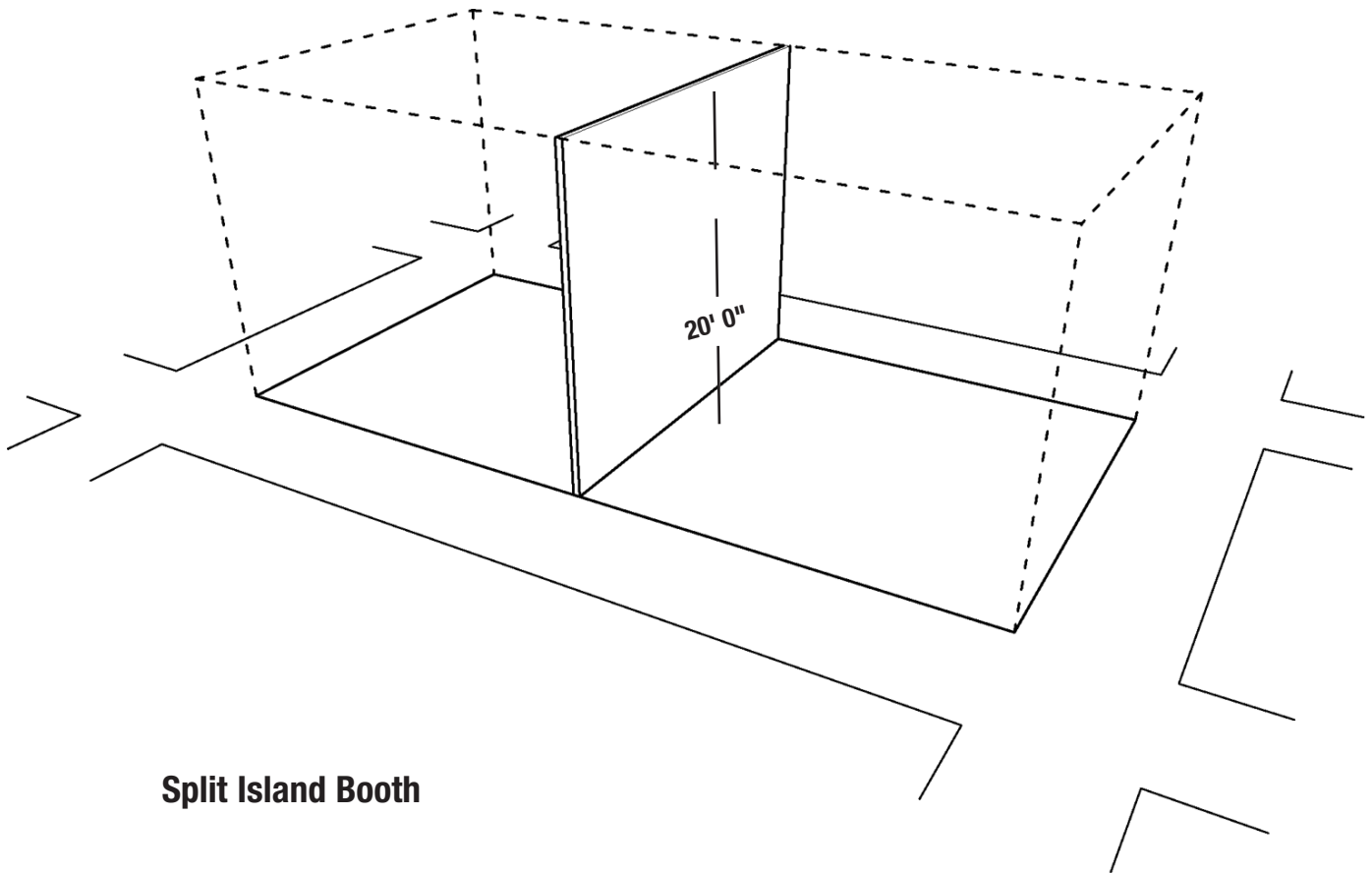

## BOOTH CONSTRUCTION | DISPLAY RULES AND REGULATIONS

### ISLAND BOOTH

An island booth is any size booth exposed to aisles on all four (4) sides. The entire cubic content of this booth may be used up the maximum content of 20' (6.0m), including signage.

Exhibitors may delete booths from the floor plan to form an island only, and only, if the total number of booths on both sides of the aisle totals 400 square feet or more (see diagram below).

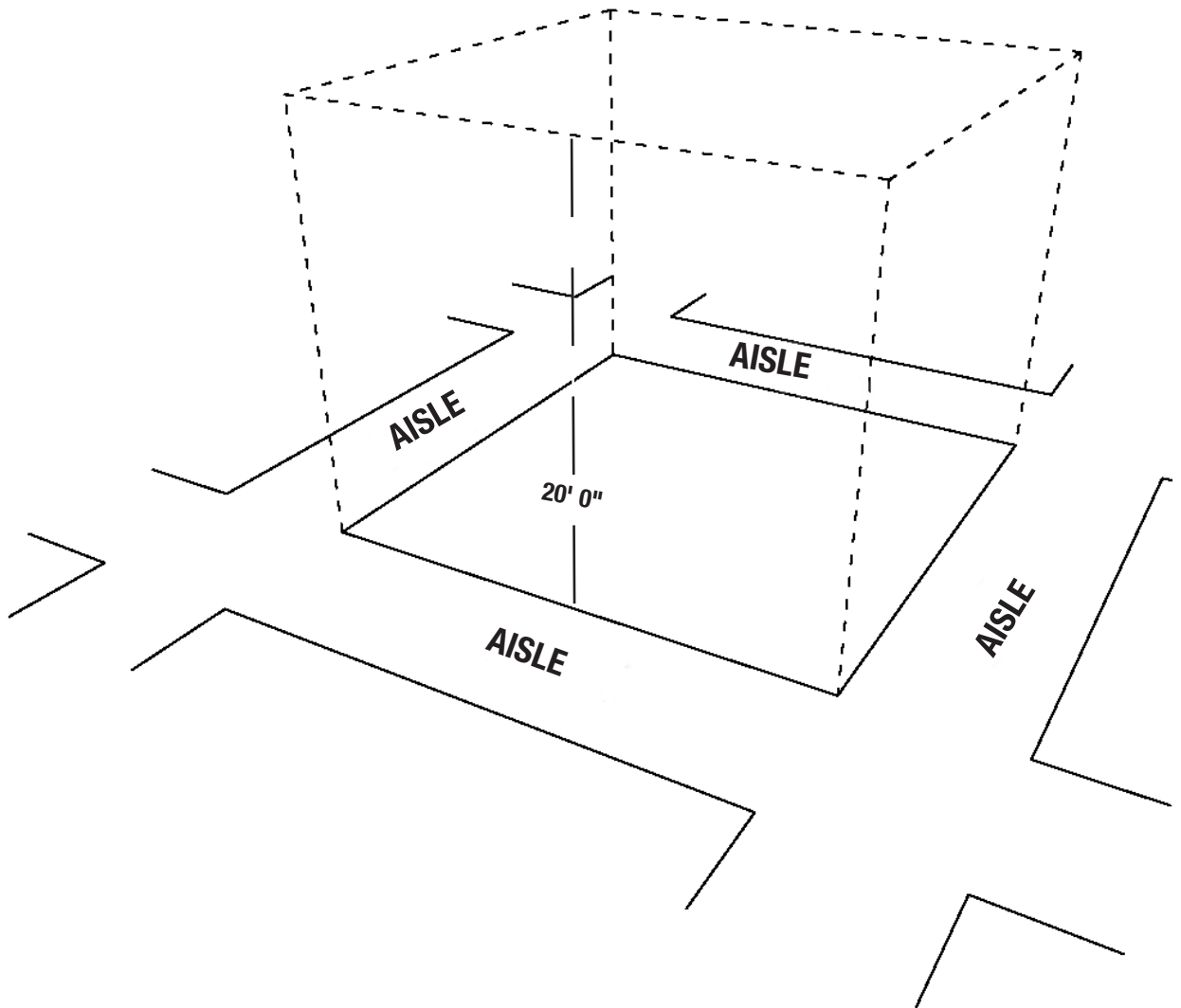

## IMPORTANT BOOTH CONSTRUCTION DISPLAY CONSIDERATIONS

### CANOPIES & CEILINGS

Canopies, including ceilings, umbrellas and canopy frames, can be either decorative or functional (such as to shade computer monitors from ambient light or for hanging products). Canopies for inline or perimeter booths should comply with line of sight requirements and may not protrude into the aisle.

The base of the canopy should not be lower than 7' (2.13m) from the floor within 5' (1.52m) of any aisle. Canopy supports should be no wider than 3" (7.62cm). This applies to any booth configuration that has a sightline restriction, such as an inline booth. Fire and safety regulations for the convention center may apply to canopies and ceilings and will be included in the Exhibitor Services Manual made available to Exhibitors 90 days prior to show opening. The convention center has reserved the right to update, change or amend its rules and regulations after publication in the Exhibitor Services Manual.

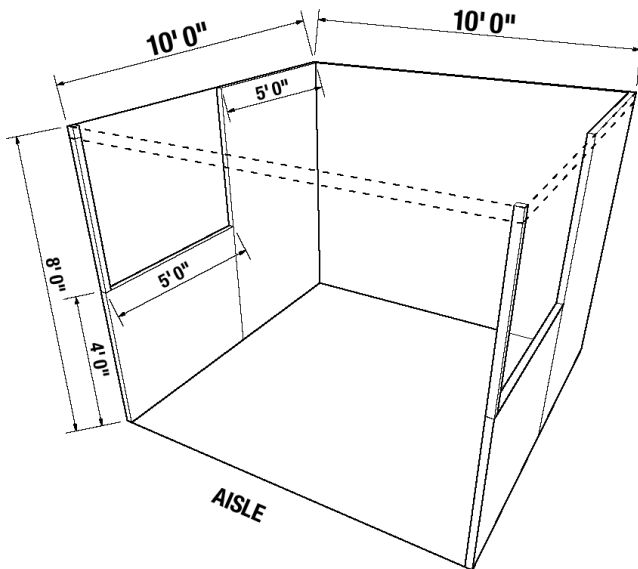

**10' X 10' INLINE BOOTH  
with Canopy**

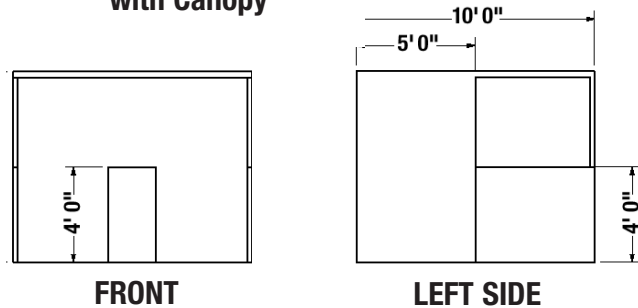

### HANGING SIGNS & GRAPHICS

Hanging signs and graphics are permitted in all peninsula, modified peninsula, split island and island booths to a maximum height of 20' (6.10m) to the top of the sign. Whether suspended from above or supported from below, they should comply with all use-of-space requirements. If within 5' (1.53m) of an adjacent booth, and if the placement complies with the use-of-space requirements, the side facing the adjacent booth should be finished and not contain any copy.

### MULTI-STORY EXHIBITS

A multi-story exhibit is permitted in all peninsula, modified peninsula, split island and island booths to a maximum height of 20' (6.10m). Multi-story exhibits require approval and building permits from the convention center and the fire marshal. Exhibitors should obtain permits early on to ensure that all time constraints are met. Additional information will be included in the Exhibitor Services Manual made available to Exhibitors 90 days prior to show opening.

## **ISSUES COMMON TO ALL BOOTH TYPES**

### **STRUCTURAL INTEGRITY**

---

All exhibit displays should be designed and erected in a manner that will withstand normal contact or vibration caused by neighboring Exhibitors, hall labors or installation/dismantling equipment such as fork lifts. Displays should be able to withstand moderate wind effects that may occur in the Exhibit Hall when freight doors are open. Exhibitor should ensure that any display fixtures such as tables, racks or shelves are designed and installed properly to support the product or marketing materials to be displayed upon them.

### **FLAMMABLE AND TOXIC MATERIALS**

---

All materials used in display construction and decorating should be made of fire retardant materials and be certified as flame retardant. Exhibitors should dispose of any waste products they generate during the exhibition in accordance with guidelines established by the Environmental Protection Agency (EPA) and the facility.

### **STORAGE**

---

Fire regulations prohibit storing product, literature, empty packing containers or packing materials behind drapes. In most cases, however, Exhibitors may store a limited supply of literature or product appropriately within the booth area, as long as these items do not impede access to utility services, create a problem or look unsightly.